

Crystal Vision

SW222 SDI/ASI 2 x 2 Switch

Providing simple and clean 2 x 2 switching between two SDI or DVB-ASI signals, the SW222 is relied on by multi-channel broadcasters. It is equally at home as an emergency transmission switch to avoid broken equipment, or to manually bypass products requiring maintenance on a 24 hour station.

Each of the two inputs can be switched to either or both of two outputs (A and B), with up to four relocked outputs of each switched signal available. There's the choice of independent or opposite paired outputs. With independent operation you can control the selection separately for each output. With opposite paired outputs the switches are controlled so that output B always gets the input not selected for output A, making B a preview that will always show what will be transmitted if you change the switch.

An automatic switch away from a faulty SDI source is triggered on loss of input or invalid video (determined by loss of the sync word structure), while if the SW222 is set for ASI it will only switch on loss of input. The SW222 gives you the choice of switching between the two feeds either immediately or in the vertical blanking period (with it detecting the video standard and switching at the appropriate point) to enable a clean switch.

The SW222 offers powerful and flexible control using a combination of board edge piano switches and GPIs. Up to four GPI inputs with tally can be used for control applications such as wiring physical buttons to represent the inputs, while lamp drivers allow a bulb to be lit to indicate the input selected.

The SW222 is a 100mm x 266mm module fitting in the standard frames (available in 4U, 2U, 1U and desk top box) and allowing easy integration with any products from the range. It gives flexible outputs thanks to the choice of four rear modules to suit all applications - the RM01, RM02, RM18 and RM38. Bringing an extra layer of security, the RM38 provides relay bypass protection on power failure or board removal, preventing signal loss by mechanically connecting the inputs of the SW222 to its outputs whenever the supply to the RM38 is interrupted.



- 10 bit SDI/ASI 2 x 2 switch
- Can be used as emergency switch or to bypass products requiring maintenance
- Maximum of four relocked SDI outputs per channel or two DVB-ASI outputs per channel
- Automatic detection of faulty inputs
- Switch immediately or in vertical blanking
- Relay bypass protection available with RM38 rear module
- Space-saving: 100mm x 266mm module allows 12 SW222 in 2U (24 in 4U, six in 1U and two in desk top box)
- Powerful and flexible control from board edge piano switches or GPIs

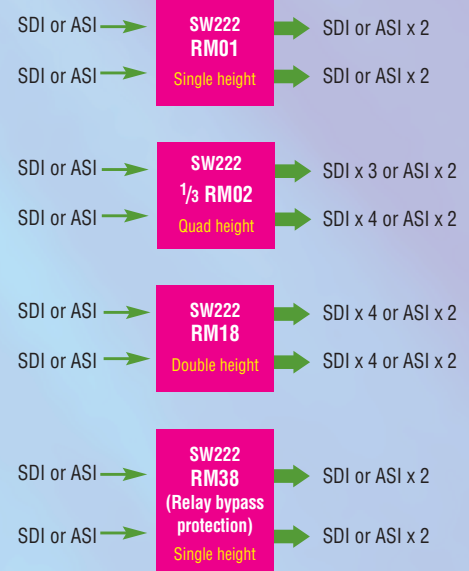

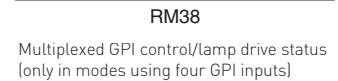
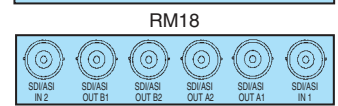
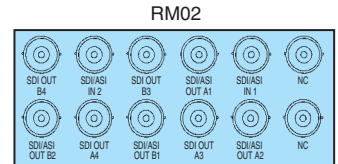
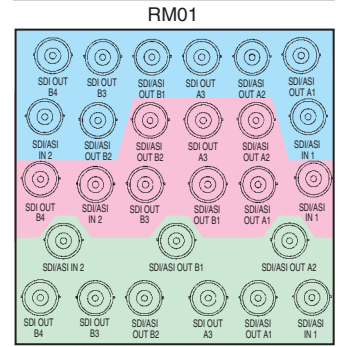
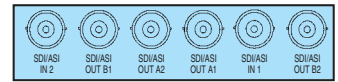
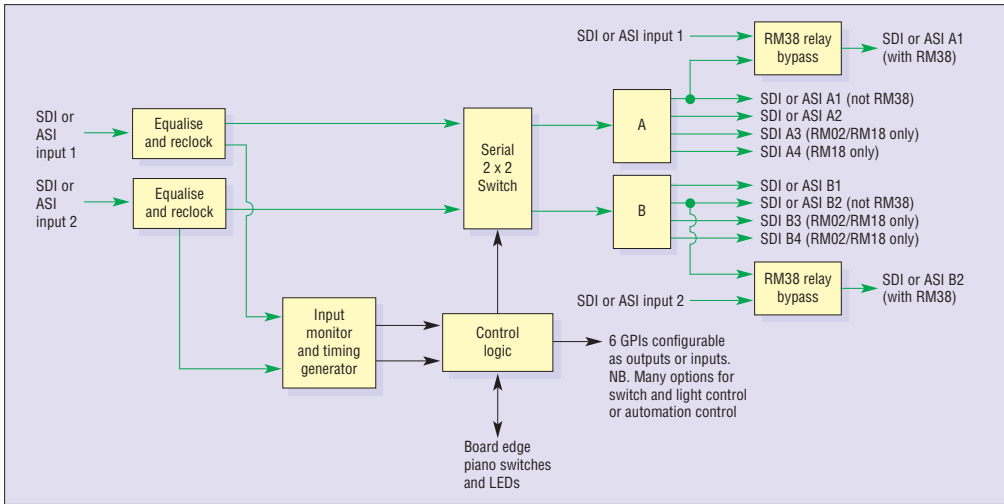

Multiplexed GPI control/lamp drive status (only in modes using four GPI inputs)

MECHANICAL

Standard Crystal Vision module 266mm x 100mm
Weight: 135g
Power consumption: 5 Watts

VIDEO INPUTS

Two SDI or DVB-ASI inputs (1 and 2)
270Mbit SDI to EBU 3267-E and SMPTE 259M and DVB-ASI to EN 50083-9
Cable equalisation >200m Belden 8281 or equivalent
Auto 625/525 line selection

VIDEO OUTPUTS

Two independent ports with up to four buffered outputs of each, depending on the frame rear module fitted
Outputs available with RM01: SDI/ASI A1 and SDI/ASI A2; SDI/ASI B1 and SDI/ASI B2
Outputs available with RM02: SDI/ASI A1, SDI/ASI A2 and SDI A3; SDI/ASI B1, SDI/ASI B2, SDI B3 and SDI B4
Outputs available with RM18: SDI/ASI A1, SDI/ASI A2, SDI A3 and SDI A4; SDI/ASI B1, SDI/ASI B2, SDI B3 and SDI B4
Outputs available with RM38: SDI/ASI A1 (relay bypass protected) and SDI/ASI A2; SDI/ASI B1 and SDI/ASI B2 (relay bypass protected)
Relocked 270Mbit SDI to EBU 3267-E and SMPTE 259M and DVB-ASI to EN 50083-9

RELAY BYPASS PROTECTION

The RM38 rear module provides relay bypass protection. An electromechanical relay switch needs power to hold the switch in one state and will revert to the other state (board bypass) on loss of power. It prevents signal loss by mechanically connecting the inputs of the SW222 to its outputs on complete frame power failure or board removal. Input 1 is connected to main output 1 and input 2 is connected to secondary output 2

DELAY THROUGH BOARD

20ns

SWITCHING

Electronic switching between SAV and EAV at line 6 (625 line) and line 10 (525 line) or immediate switching if input missing (or immediate switching selected on piano switch)
Switching can be controlled from the board edge or by GPI
GPI control can be configured in six different ways, allowing for direct connection to lamps and switches in a number of different configurations, or to an automation system

AUTO SWITCHING ON MISSING INPUT

The outputs of the switch can be configured to automatically switch away from a missing input. The switch will return to the previous selection when the input returns. An input is considered missing if successive SAV and EAV sequences are not detected for three consecutive line periods

GPI INPUT LEVELS

Active: connect to ground
Inactive: high impedance or 3 to 45 volts
Input current <750uA

GPI OUTPUT LEVELS

Lamp driver outputs, active low, with pull-ups
Links can be replaced with resistors to drive LED if requested when ordered
Max current -300mA
Lamp drive is multiplexed with GPI inputs in some modes to allow for four control inputs and four lamps. This can be switched off

LED INDICATION OF:

Power supplies
625/525 input detected
Inputs present
Selected input for each output

PIANO SWITCH CONTROL OF:

Switch inputs
Auto switch away from missing SDI input
Immediate switch without waiting for correct line in vertical interval
GPI control mode (see next section)

Crystal Vision Ltd.

Lion Technology Park
Station Road East
Whittlesford, Cambridge
CB22 4WL, England
Tel: +44 (0)1223 497049
Fax: +44 (0)1223 497059
E-mail: sales@crystalvision.tv
www.crystalvision.tv

ORDERING INFORMATION

SW222	SDI/ASI 2 x 2 switch
Indigo 4	4U frame with passive front panel for up to 24 Crystal Vision modules
Indigo 4SE	4U frame with passive front panel fitted with Statesman CPU for up to 24 Crystal Vision modules
Indigo 2	2U frame with passive front panel for up to 12 Crystal Vision modules
Indigo 2AE	2U frame with active front panel for up to 12 Crystal Vision modules
Indigo 2SE	2U frame with passive front panel fitted with Statesman CPU for up to 12 Crystal Vision modules
Indigo 1	1U frame with passive front panel for up to six Crystal Vision modules
Indigo 1A	1U frame with active front panel for up to six Crystal Vision modules
Indigo 1S	1U frame with passive front panel fitted with Statesman CPU for up to six Crystal Vision modules
Indigo DT	Desk top box with passive front panel for up to two Crystal Vision modules
Indigo DTA	Desk top box with active front panel for up to two Crystal Vision modules
Indigo DTS	Desk top box with passive front panel fitted with Statesman CPU for up to two Crystal Vision modules
RM01	Single slot frame rear module. Allows maximum number of SW222 in frame (24 in 4U, 12 in 2U, six in 1U, two in desk top box). Gives access to two outputs per channel (all ASI compatible)
RM02	Four slot frame rear module. One rear module used for three SW222, allowing 18 SW222 in 4U and nine in 2U. Gives access to three outputs of the first channel and four of the second (first two outputs in each case are ASI compatible)
RM18	Two slot frame rear module. Allows 12 SW222 in 4U, six in 2U, three in 1U and one in desk top box. Gives access to four outputs per channel (first two outputs in each case are ASI compatible)
RM38	Single slot frame rear module. Allows maximum number of SW222 in frame (24 in 4U, 12 in 2U, six in 1U, two in desk top box). Provides relay bypass protection. Gives access to two outputs per channel (all ASI compatible)