

digital keying modular  
interface audio  
converters analogue video

# ADC102N

Analogue to digital converter

## USER MANUAL



# ADC102N Analogue to Digital Converter

## USERS MANUAL

GD 14-11-01  
PCB Issue 4.0

### CONTENTS

<b>INTRODUCTION .....</b>	<b>3</b>
MECHANICAL.....	3
ELECTRICAL.....	3
ANALOGUE INPUT .....	3
<b>OPTIONS AVAILABLE FROM FRONT PANEL .....</b>	<b>4</b>
DIL SWITCH .....	4
LEDs .....	5
LINKS .....	5
<b>INSTALLATION INFORMATION.....</b>	<b>6</b>
<b>GENERAL PURPOSE INTERFACE .....</b>	<b>6</b>
GPI CONNECTIONS.....	7
<b>FR2AV 2U FRAME FOR 12 MODULES .....</b>	<b>8</b>
<b>FR1AV 1U FRAME FOR 6 MODULES .....</b>	<b>8</b>
<b>DTBAV 1U FRAME FOR 2 MODULES .....</b>	<b>8</b>
RM01 CONNECTIONS.....	9
RM18 CONNECTIONS.....	9
<b>FR1-6 1U FRAME FOR 6 MODULES.....</b>	<b>10</b>
VIDEO CONNECTIONS.....	10
<b>FR2-12 2U FRAME FOR 12 MODULES.....</b>	<b>10</b>
VIDEO CONNECTIONS.....	10
<b>FR2-8 2U FRAME FOR 8 MODULES.....</b>	<b>10</b>
VIDEO CONNECTIONS.....	11

## INTRODUCTION

The ADC102N is a 10-bit Near broadcast Analogue Component to Serial Digital converter with a range of selectable analogue component inputs and 2 serial digital outputs. It is very compact with 6 modules fitting in a 1U frame or 12 in a 2U frame. It will accept either 625 or 525 line input, with automatic detection.

The ADC102N will plug into the front of either the range of Crystal Vision Universal video frames, or the AV range with its selectable audio and video rear connector modules. This allows a mixture of Crystal Vision module to used side by side in a single frame.

The hinged front panel of the case reveals user control of the card, and also LED indication of status. There is an 8-way piano switch that allows selection of some user options, and a rotary switch for test pattern selection. Further configuration is possible using movable links.

## SPECIFICATION

### MECHANICAL

Dimensions	100mm x 266mm module with DIN 41612 connector. User adjustments and indication at end of board to allow access from hinged front panel.
Weight	210g

### ELECTRICAL

Analogue Input	Y,Cb,Cr and sync or RGB and sync 700mV into 75 ohms. (Y and Green 1 volt with syncs). Sync input 300mV or 2 volt into 75 ohms. DIL switch selection of Y,Cb,Cr/RGB, setup, and Betacam levels. Auto or manual 525/625 selection. +/- 2us adjustment of picture position from syncs.
Outputs	2 x 270Mb/s serial digital to EBU Tech 3267-E & SMPTE 259M. Each will drive >200m Belden 8281 or equivalent. DIL switch selection of Y, Cb, Cr/RGB, and set-up.

Movable link on board can select Betacam levels for Cb and Cr, which gives 700mV for 75% colour bars, instead of standard 700mV for 100%bars.

Power Consumption 6.25W.

## ANALOGUE PERFORMANCE

### Frequency Response:

Luminance	$\pm 0.2\text{dB}$ 0 to 5.75MHz.
Chrominance	$\pm 0.2\text{dB}$ 0 to 2.75MHz.
Noise	< -60dB weighted luminance or chrominance.
Gain Error	<1%
RGB matrix error	<1%
Chroma/Luma delay inequality	<5ns
Sampling	Sampled to 10-bit precision at 13.5Mhz Y and 6.75Mhz Cb and Cr.
Blanking	To 601 specification vertically, with selectable VBI blanking PAL lines 7-22 & 319-335 and NTSC lines 7-20 & 270-278.

### Options available from Front Panel

#### VIEW OF BOARD FRONT

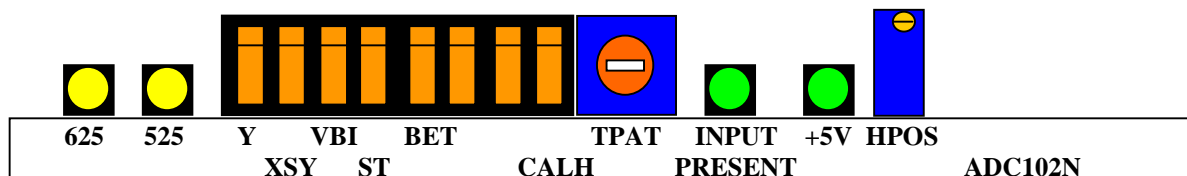

#### DIL SWITCH

		Up	Down
1	Y	RGB Input	Y,Cb,Cr Input
2	XSY	Sync on Y & G	External Syncs
3	VBI	VBI blanked	VBI unblanked
4	ST		Compensates for setup on incoming signal (525 only)
5	BET	Normal chrominance levels on I/P	Betacam levels on Input
6			
7			
8	CALH	Picture position User adjust	Default picture position (RV10)

#### FRONT PANEL LEDs

Lock Error	Red	Serial digital Errors detected.
625	Yellow	625 line input detected. Only valid if I/P present.

525	Yellow	525 line input detected. Only valid if I/P present.
Input Present	Green	Valid Serial Digital input detected.
+5V	Green	Power supply voltage present.

### Horizontal position adjustment

Allows adjustment of horizontal picture position up to +/- 2us from reference sync input when selected with DIL8.

### 625/525 Line Mode selection

625/525 line selection is controlled by a link on J1 or J2.

There are 11 potentiometers on the board. These are factory set and should not need adjustment.

### **Link positions.**

The positions of the jumper links are shown below.

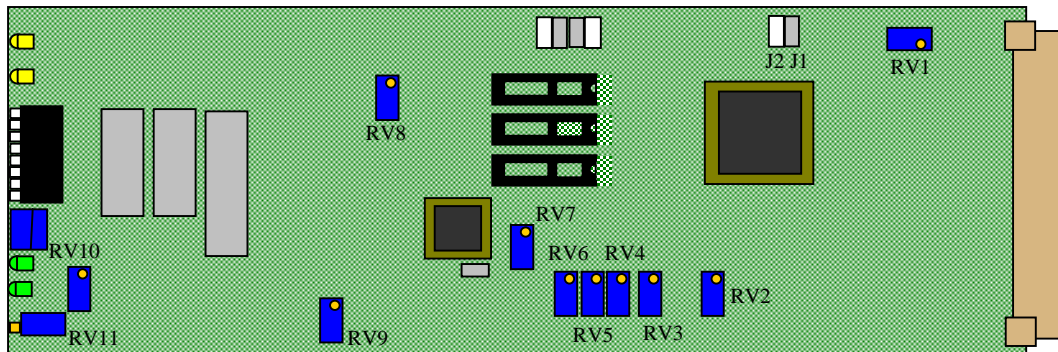

### Link position

Position Link Fitted	Function
J1	Auto
J2	525
Not fitted	625

## Factory Presets

The following Link and Pot information is given for reference only and should not need adjusting.

- J1 closed (auto line selection)
- J2 open
  
- RV1 Auto standard reference (With 625 input set for 36.6 ms on TP12)
- RV2 YC offset
- RV3 V Gain
- RV4 U Gain
- RV5 CC Ref
- RV6 Y Gain
- RV7 YC Ref
- RV8 SetUp (NTSC only)
- RV9 VCO free running frequency
- RV10 Picture position default.
- RV11 Picture position User adjust.

## General Purpose Interface

Remote control is possible by GPI. In GPI configuration, remote switches can be used to emulate some of the front panel switches. Normally pulled up on-board to +5V via 2k2Ω.

### GPI Functions

	OPEN	CONNECT TO GROUND
'a'		
'b'		
'c'	RGB Input selected	Y,Cb,Cr Input selected
'd'	Sync present on Y and G	External Sync selected
'e'	VBI blanked	VBI unblanked
'f'		Setup on Y compensation

### GPI CONNECTIONS

Each slot has an associated set of connections on the frame rear-panel remote connectors. The tables below show the GPI connections described above.

**Remote 1 and Remote 3:** 26 way high density D-type **sockets**.

[+5V @ 500mA is pin 1 FR-AV]. Frame ground is pin 2.

**Remote 2 and Remote 4:** 26 way high density D-type **plugs**.

[+5V @ 500mA is Remote 2 pin 15 FR-AV]. Frame ground is pin 6.

Table shows Pin number (Remote Plug/Socket number)

FR1 Slot No.	FR2 Slot No.	'a' pin no.	'b' pin no.	'c' pin no.	'd' pin no.	'e' pin no.	'f' pin no.
1	1	8 (1)	9 (1)	18 (1)	26 (1)	19 (2)	20 (2)
2	2	7 (1)	16 (1)	17 (1)	25 (1)	10 (2)	11 (2)
	3	8 (3)	9 (3)	18 (3)	26 (3)	19 (4)	20 (4)
	4	7 (3)	16 (3)	17 (3)	25 (3)	10 (4)	11 (4)
3	5	5 (1)	6 (1)	15 (1)	24 (1)	1 (2)	2 (2)
4	6	4 (1)	14 (1)	13 (1)	23 (1)	3 (2)	4 (2)
	7	5 (3)	6 (3)	15 (3)	24 (3)	1 (4)	2 (4)
	8	4 (3)	14 (3)	13 (3)	23 (3)	3 (4)	4 (4)
5	9	3 (1)	12 (1)	22 (1)	21 (1)	12 (2)	13 (2)
6	10	10 (1)	11 (1)	19 (1)	20 (1)	21 (2)	22 (2)
	11	3 (3)	12 (3)	22 (3)	21 (3)	12 (4)	13 (4)
	12	10 (3)	11 (3)	19 (3)	20 (3)	21 (4)	22 (4)

### DTBAV GPI CONNECTIONS

**Remote 15 way D-type socket.**  
Frame ground is pin 15.

Table shows Pin number

Slot no.	'a' pin no.	'b' pin no.	'c' pin no.	'd' pin no.	'e' pin no.	'f' pin no.
1	1	2	3	4	5	6
2	9	10	11	12	13	14

### FR2-8 FRAME

**Remote 1 and Remote 2:** 26 way high density D-type sockets. Frame ground is pin 1.  
PSU Relay connection on pin 10.

Table shows Pin number (Remote Socket number)

Slot no.	'a' pin no.	'b' pin no.	'c' pin no.	'd' pin no.	'e' pin no.	'f' pin no.
1	8 (1)	9 (1)	17 (1)	18 (1)	25 (1)	26 (1)
2	6 (1)	7 (1)	15 (1)	16 (1)	23 (1)	24 (1)
3	8 (2)	9 (2)	17 (2)	18 (2)	25 (2)	26 (2)
4	6 (2)	7 (2)	15 (2)	16 (2)	23 (2)	24 (2)
5	4 (1)	5 (1)	13 (1)	14 (1)	21 (1)	22 (1)
6	2 (1)	3 (1)	11 (1)	12 (1)	19 (1)	20 (1)
7	4 (2)	5 (2)	13 (2)	14 (2)	21 (2)	22 (2)
8	2 (2)	3 (2)	11 (2)	12 (2)	19 (2)	20 (2)

Frame configurations

- FR2AV 2U Frame for 12 Modules
- FR1AV 1U Frame for 6 Modules
- DTBAV Desk top Frame for 2 Modules



The 2U FR2AV frame will house up to 12 modules and dual power supplies. A hinged front panel gives access to the PSU and all modules. The universal frame wiring system allows any of the interface range of modules to be fitted in any position with the use of removable rear modules.

All modules can be plugged in and removed while the frame is powered without damage.

Rear Connectors

RM01 Connections

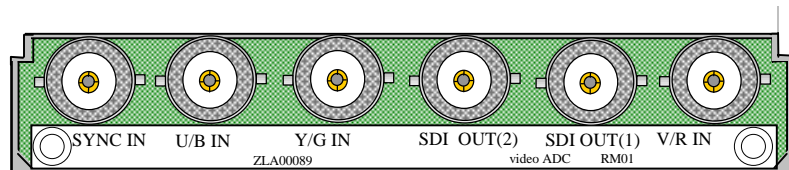

V/R IN	Cr or R Component Input
SDI OUT(1)	Serial Digital Output.
SDI OUT(2)	Serial Digital Output.
Y/G IN	Y or G Component Input
U/B IN	Cb or B Component Input
SYNC IN	External Sync Input



## RM02 Connections

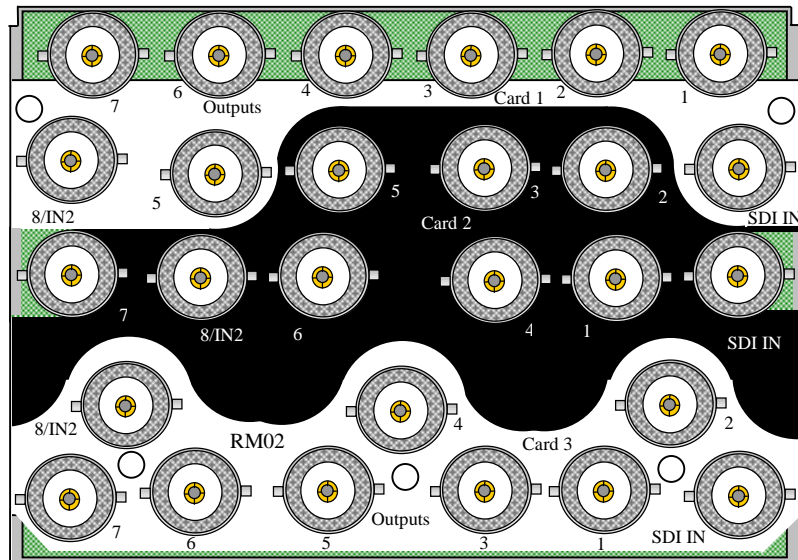

SDI IN	Serial Digital Input
1	Reclocked Serial Digital Output
2	Y/G Input
3	Y/G Input
4	U/B Input
5	V/R Input
6	V/R Input
7	External Sync Input
8/IN2	External Sync Input

## RM18 Connections

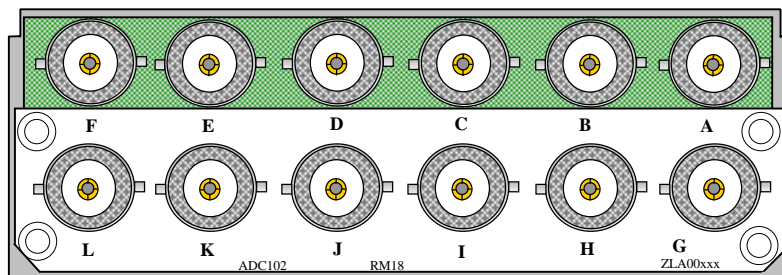

A	n/c
B	Serial Digital Output.
C	Serial Digital Output.
D	Cr or R Component Input
E	External Sync Input
F	External Sync Loop-through
G	n/c
H	Y or G Component Input
I	Y or G Component Input
J	Cb or B Component Input
K	Cb or B Component Input
L	Cr or R Component Input

FR1-6 1U Frame for 6 Modules.  
 FR2-12 2U Frame for 12 Modules.  
 FR2-8 2U Frame for 6 Modules.

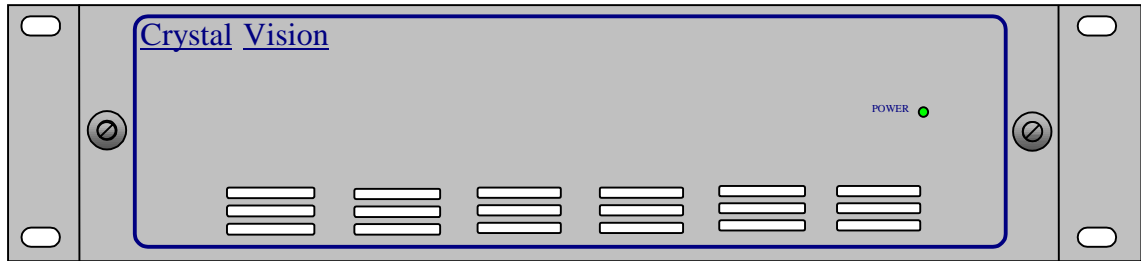

The FR1-6, FR2-8, FR2-12 frames for 6 & 12 modules include rear panel BNC connections and plug-in power supply. A hinged front panel gives access to the PSU and all modules. The universal frame wiring system allows any of the video interface range of modules to be fitted in any position. The 1U FR1-6 frame houses up to 6 modules and a single power supply. The 2U FR2-12 frame houses up to 12 modules and dual power supplies. The 2U FR2-8 frame houses 8 modules each with extra rear panel BNC connections. The modules can be plugged in and removed while the frame is powered without damage.

FR1-6, FR2-12 & DTB-2 Rear Connections

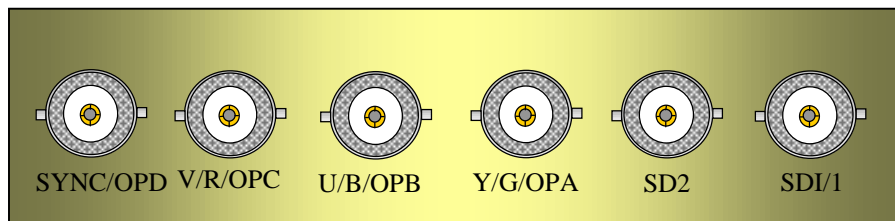

SDI/1	Serial Digital Output
SD2	Serial Digital Output.
Y/G/OPA	Y or G Component Input
U/B/OPB	U or B Component Input
V/R/OPC	V or R Component Input
SYNC/OPD	External Sync Input

## FR2-8 Rear Connections

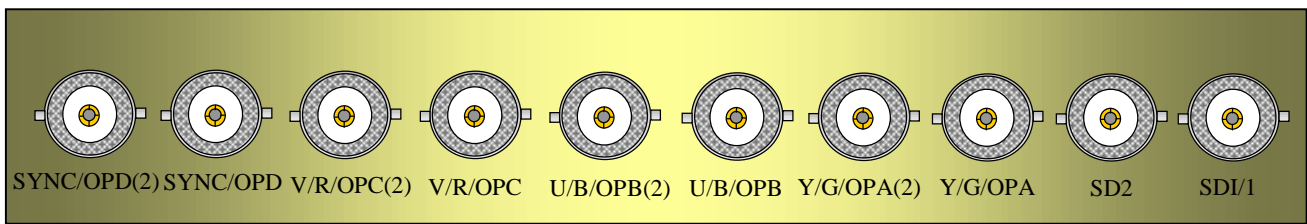

SDI/1	Serial Digital Output.
SD2	Serial Digital Output.
Y/G/OPA	Y or G Component Input
Y/G/OPA(2)	Y or G Component Loop-through
U/B/OPB	U or B Component Input
U/B/OPB(2)	U or B Component Loop-through
V/R/OPC	V or R Component Input
V/R/OPC(2)	V or R Component Loop-through
SYNC/OPD	External Sync Input
SYNC/OPD(2)	External Sync Loop-through