



digital keying modular
interface audio
converters analogue video

DAC102FK

Digital to analogue converter

USER MANUAL



DAC102FK RGB/YUV DAC

USERS MANUAL

GD 13-11-01
PCB Issue 3.0

CONTENTS

INTRODUCTION	3
MECHANICAL.....	3
ELECTRICAL.....	3
ANALOGUE OUTPUT	4
OPTIONS AVAILABLE FROM FRONT PANEL	4
DIL SWITCH	4
LEDs	5
GAIN	5
INSTALLATION INFORMATION.....	6
GENERAL PURPOSE INTERFACE	6
GPI CONNECTIONS.....	6
FR2AV 2U FRAME FOR 12 MODULES	8
FR1AV 1U FRAME FOR 6 MODULES	8
DTBAV 1U FRAME FOR 2 MODULES	8
RM01 CONNECTIONS	8
RM02 CONNECTIONS	9
RM18 CONNECTIONS	9
FR1-6 1U FRAME FOR 6 MODULES.....	10
VIDEO CONNECTIONS.....	10
FR2-12 2U FRAME FOR 12 MODULES.....	10
VIDEO CONNECTIONS.....	10
FR2-8 2U FRAME FOR 8 MODULES.....	10
VIDEO CONNECTIONS.....	10

INTRODUCTION

The DAC102FK is a 10-bit broadcast Key Output only, Serial Digital to Analogue Component converter with a range of selectable analogue component outputs. It is very compact with 6 modules fitting in a 1U frame or 12 in a 2U frame, and offers remarkable value for money. It will accept either 625 or 525 line input, with automatic detection. Outputs available are RGB or Y and sync, and a reclocking serial loop through. An extra set of analogue output is available if a position in the rack frame is left unused or if the module is fitted in an FR2-8 frame. The DAC102FK will plug into the front of either the range of Crystal Vision Universal video frames, or the AV range with its selectable audio and video rear connector modules. This allows a mixture of Crystal Vision module to be used side by side in a single frame.

The hinged front panel of the case reveals user control of the card, and also LED indication of status. There is an 8-way piano switch that allows selection of some user options. Further configuration is possible using movable links.

SPECIFICATION

MECHANICAL

Dimensions 100mm x 266mm module with DIN 41612 connector. User adjustments and indication at end of board to allow access from hinged front panel.

Weight 210g

ELECTRICAL

Input 270Mb/s serial digital to EBU Tech 3267-E and SMPTE-259M.
Cable equalisation >200m Belden 8281 or equivalent.
Auto or manual 525/625 selection.

Outputs Reclocked Serial Loop through.
Each will drive >200m Belden 8281 or equivalent.
2 output of Y and sync or RGB and sync 700mV into 75 ohms.
(Y and Green 1 volt with syncs). Sync output 2 volt into 75 ohms.

2nd set of outputs is available if the module is fitted in the FR2-8 or AV frames.

DIL switch selection of Y/RGB, and set-up.

Power Consumption 6W.

ANALOGUE OUTPUT

Frequency Response:

Luminance	$\pm 0.1\text{dB}$ 0 to 5.75MHz.
Noise	< -60dB weighted luminance or chrominance.
Gain Error	<1%
RGB matrix error	<1%
Blanking (selectable)	To 601 specification horizontally and vertically, with selectable VBI blanking PAL lines 7-22 & 319-335 and NTSC lines 7-20 & 270-278. Selectable shaped analogue blanking from DIP switch.

INSTALLATION INFORMATION

VIEW OF BOARD FRONT

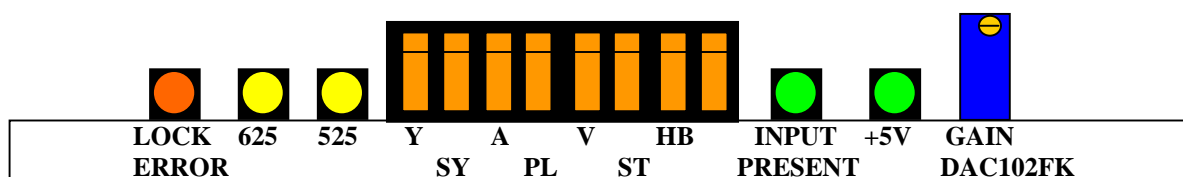

DIP SWITCH

		Up	Down
1	Y	RGB	Y,Cb,Cr
2	SY	Sync on Y & G	Sync disabled
3	A	Auto Line Standard	625/525 selected by DIL4
4	PL	PAL (auto not selected)	NTSC (auto not selected)
5	V	VBI blanked	VBI unblanked
6	ST	Set-up not selected	7.5 IRE added to Y (525 only)
7	HB	Digital blanking	Analogue blanking
8			

FRONT PANEL LEDs

Lock Error	Red	Serial digital Errors detected.
625	Yellow	625 line input detected. Only valid if I/P present.
525	Yellow	525 line input detected. Only valid if I/P present.
Input Present	Green	Valid Serial Digital input detected.
+5V	Green	Power supply voltage present.

There are 9 potentiometers on the board. These are factory set and should not need adjustment.

Link positions.

The positions of the jumper links are shown below.

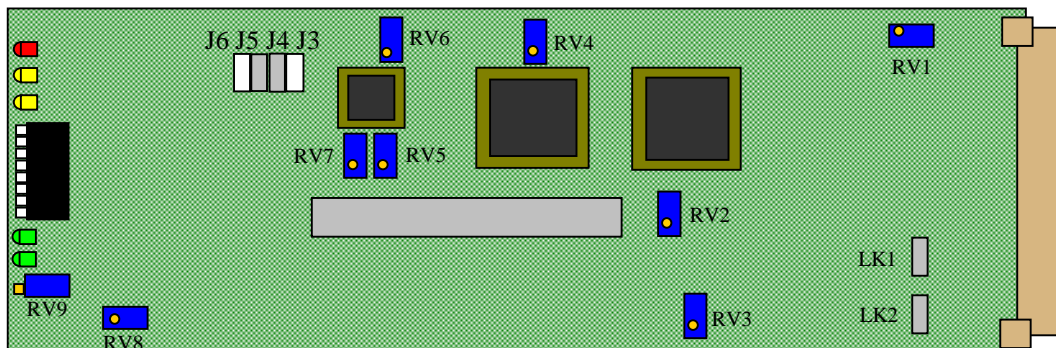

Factory Presets

The following Link and Pot information is given for reference only and should not need adjusting.

LK1 closed
LK2 closed

RV1 Serial Digital Input PLL adjustment.
RV2 V Gain
RV3 U Gain
RV4 Setup Amplitude
RV5 YGBR Ref (sets black level)
RV6 Sync Amplitude
RV7 UV Ref (sets Cb,Cr black level)
RV8 Auto standard reference (With 625 input set for 36.6 ms on U14 pin 13)
RV9 Overall Gain (board edge)

General Purpose Interface

Remote control is possible by GPI. In GPI configuration, remote switches can be used to emulate some of the front panel switches. Normally pulled up on-board to +5V via 2k2Ω.

GPI Functions

	OPEN	CONNECT TO GROUND
'a'		
'b'		
'c'	RGB Output selected	Y,Cb,Cr Output selected
'd'	Sync present on Y and G	Sync removed from Y and G
'e'	Auto line standard selected	DIL4 state selected
'f'		

GPI CONNECTIONS

Each slot has an associated set of connections on the frame rear-panel remote connectors. The tables below show the GPI connections described above.

Remote 1 and Remote 3: 26 way high density D-type **sockets**.

[+5V @ 500mA is pin 1 FR-AV]. Frame ground is pin 2.

Remote 2 and Remote 4: 26 way high density D-type **plugs**.

[+5V @ 500mA is Remote 2 pin 15 FR-AV]. Frame ground is pin 6.

Table shows Pin number (Remote Plug/Socket number)

FR1 Slot No.	FR2 Slot No.	'a' pin no.	'b' pin no.	'c' pin no.	'd' pin no.	'e' pin no.	'f' pin no.
1	1	8 (1)	9 (1)	18 (1)	26 (1)	19 (2)	20 (2)
2	2	7 (1)	16 (1)	17 (1)	25 (1)	10 (2)	11 (2)
	3	8 (3)	9 (3)	18 (3)	26 (3)	19 (4)	20 (4)
	4	7 (3)	16 (3)	17 (3)	25 (3)	10 (4)	11 (4)
3	5	5 (1)	6 (1)	15 (1)	24 (1)	1 (2)	2 (2)
4	6	4 (1)	14 (1)	13 (1)	23 (1)	3 (2)	4 (2)
	7	5 (3)	6 (3)	15 (3)	24 (3)	1 (4)	2 (4)
	8	4 (3)	14 (3)	13 (3)	23 (3)	3 (4)	4 (4)
5	9	3 (1)	12 (1)	22 (1)	21 (1)	12 (2)	13 (2)
6	10	10 (1)	11 (1)	19 (1)	20 (1)	21 (2)	22 (2)
	11	3 (3)	12 (3)	22 (3)	21 (3)	12 (4)	13 (4)
	12	10 (3)	11 (3)	19 (3)	20 (3)	21 (4)	22 (4)

DTBAV GPI CONNECTIONS

Remote 15 way D-type socket.

Frame ground is pin 15.

Table shows Pin number

Slot no.	'a' pin no.	'b' pin no.	'c' pin no.	'd' pin no.	'e' pin no.	'f' pin no.
1	1	2	3	4	5	6
2	9	10	11	12	13	14

FR2-8 FRAME

Remote 1 and Remote 2: 26 way high density D-type **sockets**. Frame ground is pin 1.

PSU Relay connection on pin 10.

Table shows Pin number (Remote Socket number)

Slot no.	'a' pin no.	'b' pin no.	'c' pin no.	'd' pin no.	'e' pin no.	'f' pin no.
1	8 (1)	9 (1)	17 (1)	18 (1)	25 (1)	26 (1)
2	6 (1)	7 (1)	15 (1)	16 (1)	23 (1)	24 (1)
3	8 (2)	9 (2)	17 (2)	18 (2)	25 (2)	26 (2)
4	6 (2)	7 (2)	15 (2)	16 (2)	23 (2)	24 (2)
5	4 (1)	5 (1)	13 (1)	14 (1)	21 (1)	22 (1)
6	2 (1)	3 (1)	11 (1)	12 (1)	19 (1)	20 (1)
7	4 (2)	5 (2)	13 (2)	14 (2)	21 (2)	22 (2)
8	2 (2)	3 (2)	11 (2)	12 (2)	19 (2)	20 (2)

Frame configurations

FR2AV 2U Frame for 12 Modules

FR1AV 1U Frame for 6 Modules

DTBAV Desk top Frame for 2 Modules



The 2U FR2AV frame will house up to 12 modules and dual power supplies. A hinged front panel gives access to the PSU and all modules. The universal frame wiring system allows any of the interface range of modules to be fitted in any position with the use of removable rear modules.

All modules can be plugged in and removed while the frame is powered without damage.

Rear Connectors

RM01 Connections

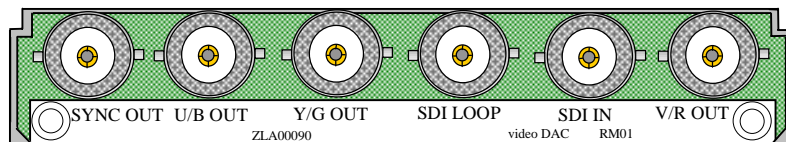

V/R OUT	R component output
SDI IN	Serial Digital Input.
SDI LOOP	Reclocked Serial Digital Output.
Y/G OUT	Y or G component output
U/B OUT	B component output
SYNC OUT	2V mixed sync output

RM02 Connections

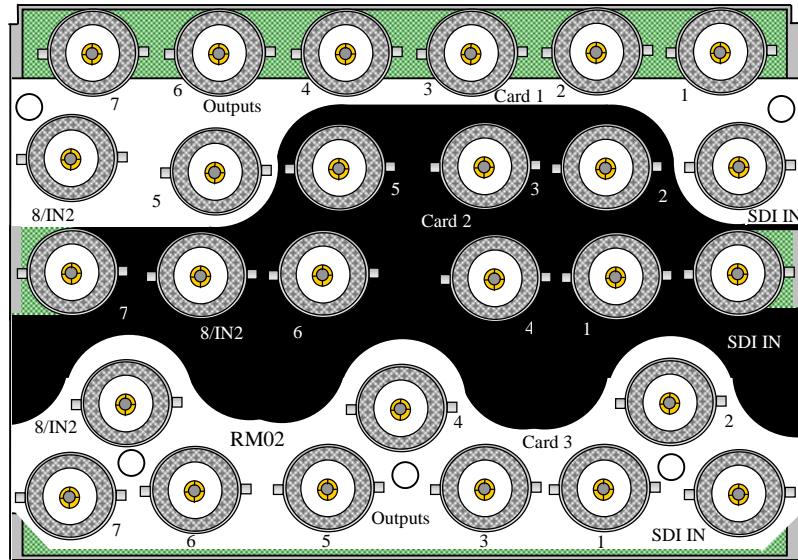

SDI IN	Serial Digital Input
1	Reclocked Serial Digital Output
2	Y/G Output
3	Y/G Output
4	B Output
5	R output
6	R Output
7	SYNC Out (2)
8/IN2	SYNC Out (1)

RM18 Connections

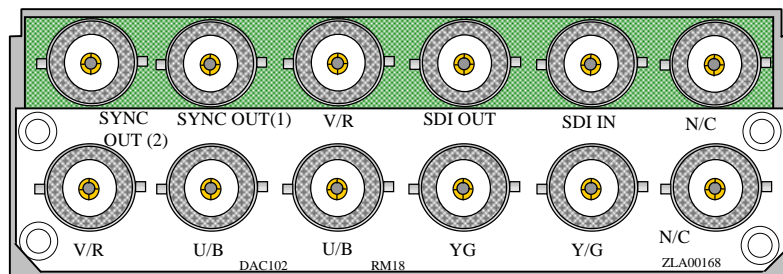

SDI IN	Serial Digital Input
SDI OUT	Reclocked Serial Digital Output
Y/G	Y/G Component Output
Y/G	Y/G Component Output
U/B	B Component Output
U/B	B Component Output
V/R	R Component Output
V/R	R Component Output
SYNC OUT(2)	SYNC Out (2)
SYNC OUT(1)	SYNC Out (1)

FR1-6 1U Frame for 6 Modules.
FR2-12 2U Frame for 12 Modules.
FR2-8 2U Frame for 6 Modules.

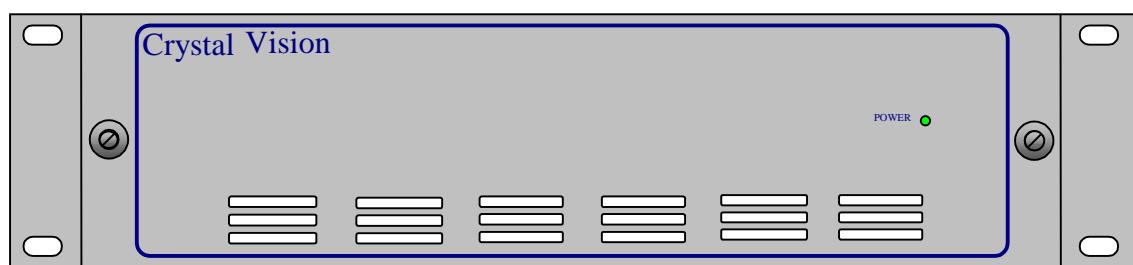

The FR1-6, FR2-8, FR2-12 frames for 6 & 12 modules include rear panel BNC connections and plug-in power supply. A hinged front panel gives access to the PSU and all modules. The universal frame wiring system allows any of the video interface range of modules to be fitted in any position. The 1U FR1-6 frame houses up to 6 modules and a single power supply. The 2U FR2-12 frame houses up to 12 modules and dual power supplies. The 2U FR2-8 frame houses 8 modules each with extra rear panel BNC connections.

The modules can be plugged in and removed while the frame is powered without damage.

FR1-6 & FR2-12 Rear Connections

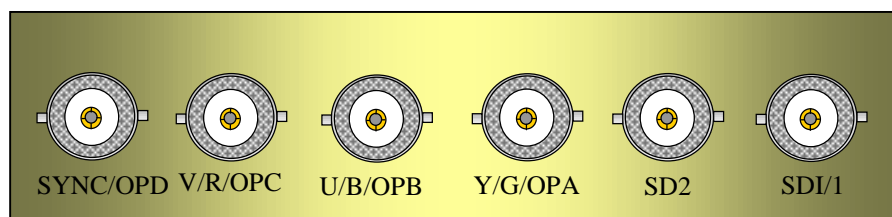

SDI/1	Serial Digital Input.
SD2	Reclocked Serial Digital Output.
Y/G/OPA	Y or G Component Output
U/B/OPB	B Component Output.
V/R/OPC	R Component Output
SYNC/OPD	2V Mixed Sync Output

FR2-8 Rear Connections

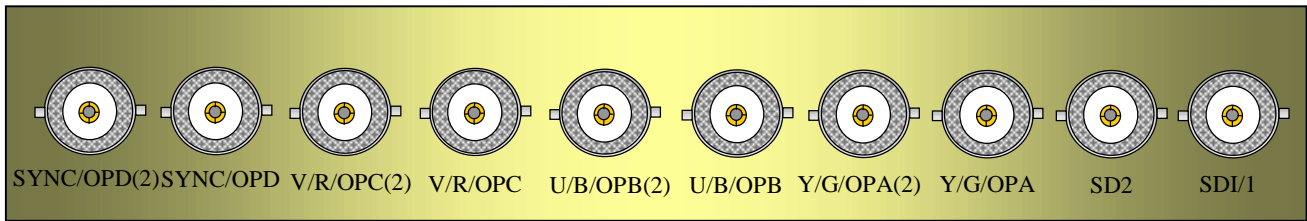

SDI/1	Serial Digital Input.
SD2	Reclocked Serial Digital Output.
Y/G/OPA	Y or G Component Output
Y/G/OPA(2)	Y or G Component Output
U/B/OPB	B Component Output
U/B/OPB(2)	B Component Output
V/R/OPC	R Component Output
V/R/OPC(2)	R Component Output
SYNC/OPD	2V Mixed Sync Output
SYNC/OPD(2)	2V Mixed Sync Output