

Contents

1	Introduction	3
2	Card edge operation	5
	Using status LEDs	5
	On-board jumper link settings	5
3	Hardware installation	6
3.1	Selecting rear connectors	6
3.2	Selecting the output module	7
	Fitting the output module	7
3.3	Changing the input termination	8
3.4	Selecting single or dual channel mode	9
3.5	Configuring the second channel input	9
3.6	Obtaining an extra output in 1-channel mode	9
3.7	Universal rear connector pinout	11
	75 Ω digital audio connections with RM01	11
	75 Ω digital audio connections with RM09 (obsolete)	12
	75 Ω digital audio connections with RM16	13
	75 Ω digital audio connections with RM02	14
	75 Ω digital audio connections with RM10 (obsolete)	15
	110 Ω IN/75 Ω OUT digital audio connections with RM13	16
	110 Ω IN/75 Ω OUT digital audio connections with RM21	17
	75 Ω IN/110 Ω OUT digital audio connections with RM12	18
	110 Ω IN/110 Ω OUT digital audio connections with RM11	19
	110 Ω IN/110 Ω OUT digital audio connections with RM03	20
	110 Ω IN/110 Ω OUT digital audio connections with RM35	21

3.8	General purpose interface	23
4	Problem solving	25
5	Specification	26

Revision 1.		
Revision 2.	Manual reformatted	13/10/06
Revision 3.	RM35 information added	23/10/06
Revision 4.	Reference to non-reclocking removed	10/01/07
Revision 5.	RM35 pin information corrected	09/01/08
Revision 6.	RM02 label information changed	08-08-12
Revision 7.	PL12 information removed. S1 information added.	18-03-14

1 Introduction

The DADA208 is a dual channel digital audio distribution amplifier with reclocked outputs.

It may be configured as a single 1-in/8-out distribution amplifier or as two 1-in/4-out distribution amplifiers.

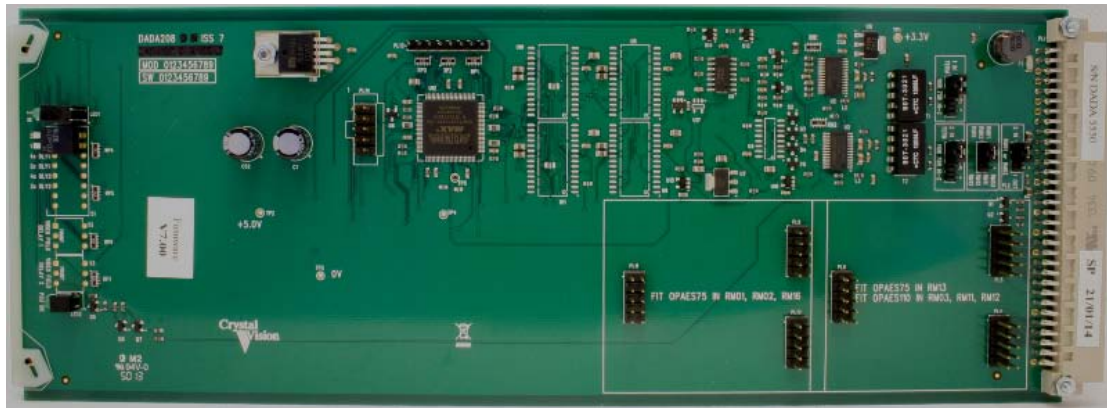

DADA208 dual digital audio DA

It supports either 75 Ω or 110 Ω inputs and selectable 'piggy-back' output modules allow either 75 Ω outputs (OPAES-75) or 110 Ω outputs (OPAES-110). The position the output module plugs into is dependent on the rear connector fitted as explained in the Installation chapter.

There is a choice of eleven rear connectors that range from single slot to quadruple slot to allow a mix between high packing density and access to all output connections. They also provide a mix between BNCs for 75 Ω connections or multiway 'D' and DIN41612 connectors for 110 Ω connections.

DADA208 is a very compact board with up to 24 modules fitting in a 4U frame when a single slot rear connector is used.

The DADA208 has LED and GPI indication of input presence/failure for each channel.

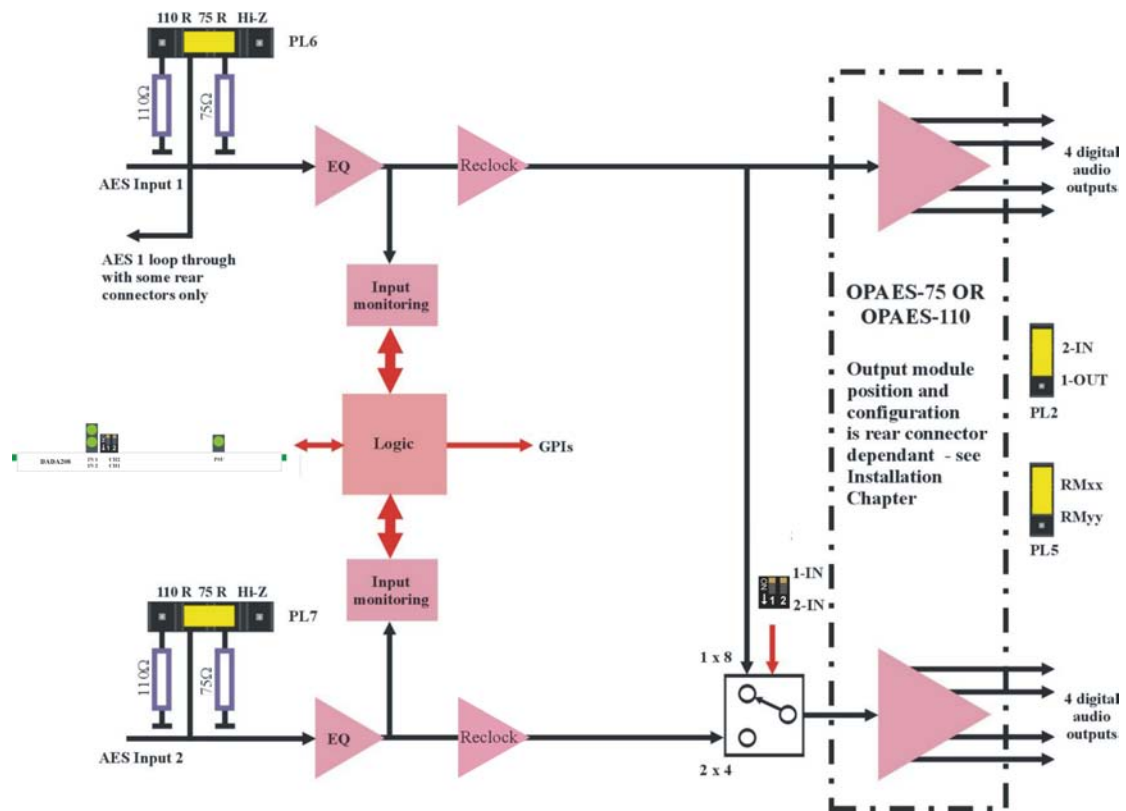

DADA208 reclocked dual digital audio DA

The main features are as follows:

- Dual 1 in 4 out or single 1 in 8 out digital audio distribution amplifier
- Choice of ten rear connectors with variable packing density and either 75Ω or 110Ω connectors
- GPI/LED input presence indication
- Card edge control

Note: This manual covers the DADA208. The DADA208N with non re-clocked outputs and the DADA208D with up to one second of delay are also available.

2 Card edge operation

The front edge of the DADA208 card provides power rail monitoring and signal status.

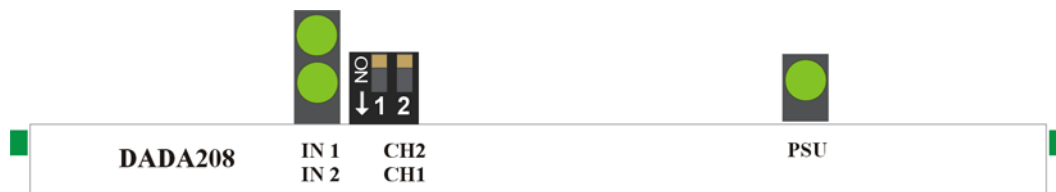

DADA208 front edge view

Using status LEDs

LED	Location/colour	Meaning when lit
IN 1	Green (top)	Digital audio present on input 1
IN 2	Green (bottom)	Digital audio present on input 2
PSU	Green	Power supply OK.

On-board jumper link and switch settings

Please refer to Chapter 3 - 'Hardware installation' to set the following options:

- Selecting rear connector and output module
- Changing the input termination – 75Ω, 110Ω or high impedance
- Changing output 2 input source – single (1 x 8) or dual (2 x 4) channel operation
- Obtaining an extra output in 1-channel mode

3 Hardware installation

The DADA208 dual channel digital audio distribution amplifier fits into all Crystal Vision rack frames. All modules can be plugged in and removed while the frame is powered without damage.

3.1 Selecting rear connectors

When used with a single height rear connector, the Indigo 4 frame will house up to 24 modules, the 2U Indigo or FR2AV frame will house up to 12 modules and dual power supplies, the 1U Indigo or FR1AV frame will house 6 modules and a single power supply. The 1U Desk Top Box has a built-in power supply and will house up to 2 modules with a single height rear connector.

The 4U, 2U and 1U frames have a hinged front panel, which gives access to the PSU and all modules. The Desk Top Box has a removable front. The universal frame wiring system allows any of the interface range of modules to be fitted in any position with the use of removable rear modules.

The following table summarises the rear connectors available.

Connector	No of Slots	No of Cards	Output Impedance and I/O
RM01	1	1	2x75Ω in/2x75Ω out per channel
RM09	1	1	2x75Ω in/1x75Ω out Ch1, 2x75Ω Ch2 with loop-through of Ch1
RM03*	1	1	2x110Ω in/4x110Ω out per channel
RM11*	1	1	2x110Ω in/4x110Ω out per channel
RM12	1	1	2x75Ω in/4x110Ω out per channel
RM21	1	1	2x110Ω in/2x75Ω out per channel
RM13	2	1	2x110Ω in/3x75Ω out per channel
RM16	2	1	2x75Ω in/4x75Ω out per channel with AES (BNC) loop-through of Ch1
RM02	4	3	2x75Ω in/3x75Ω out of Ch1 and 4x75Ω output of Ch2
RM10	4	3	2x75Ω in/3x75Ω out per channel with AES (BNC) loop-through of Ch1
RM35**	1	1	2x110Ω in/4x110Ω out per channel

Notes: Table shows no of cards per rear connector.
 Passive loop-throughs are independent of the amplifier; the module may be removed without losing the looped-through source.
 *The RM03 uses a 25 way 'D' output connector and the RM11 uses a 26 way High Density 'D' output connector. **The RM35 uses a DIN41612 64 way a+c connector

For details of fitting rear connectors, please refer to the appropriate frame manual.

3.2 Selecting the output module

There are two types of output module, one for 75Ω outputs (OPAES-75) and one for 110Ω outputs (OPAES-110). The modules are designed to fit in one of two positions near the edge connector of the board.



DADA208 dual digital audio DA

The position the output module plugs into is dependent on the rear connector fitted as the following table shows:

Rear Module	Input impedance	Output impedance	Output module	Position
RM01, RM02, RM09, RM10, RM16	75Ω BNC	75Ω BNC	OPAES75	Nearer Handle (RM01, 02, 16)
RM03, RM11	110Ω D-Type	110Ω D-Type	OPAES110	Near edge connector (RM03, RM11-13)
RM35	110Ω DIN 41612	110Ω DIN 41612	OPAES110	Near edge connector (RM03, RM11-13)
RM12	75Ω BNC	110Ω D-Type	OPAES110	Near edge connector (RM03, RM11-13)
RM13, RM21	110Ω D-Type	75Ω BNC	OPAES75	Near edge connector (RM03, RM11-13)

Note: Only one piggy-back module should be fitted at any one time. Silk-screen text for the output module positions may not include later rear connectors such as the RM09, RM10 and RM21 or RM35.

Fitting the output module

To fit an output module, proceed as follows:

- Offer up the appropriate module to the correct three-header position for the rear connector in use
- Ensure that the module is component side up
- Press down firmly ensuring that no pins are bent and that all pins line up with header sockets

3.3 Changing the input termination

Move jumper PL6 (Ch1) and/or PL7 (Ch2) to the appropriate position to set the input termination to 110 Ω , 75 Ω or high impedance.

Input 1 termination

PL 6 position	Termination	Rear connector
110R position (top)	Terminated 110 Ω	RM03, RM11, RM35
75R position (middle)	Terminated 75 Ω	RM01, RM02, RM12, *RM09, RM10, RM16
Hi-Z position (bottom)	High-impedance	*RM09, RM10, RM16

Input 2 termination

PL 7 position	Termination	Rear connector
110R position (top)	Terminated 110 Ω	RM03, RM11, RM35
75R position (top)	Terminated 75 Ω	RM01, RM02, RM12, RM09, RM10, RM16
Hi-Z position (bottom)	High-impedance	Not applicable

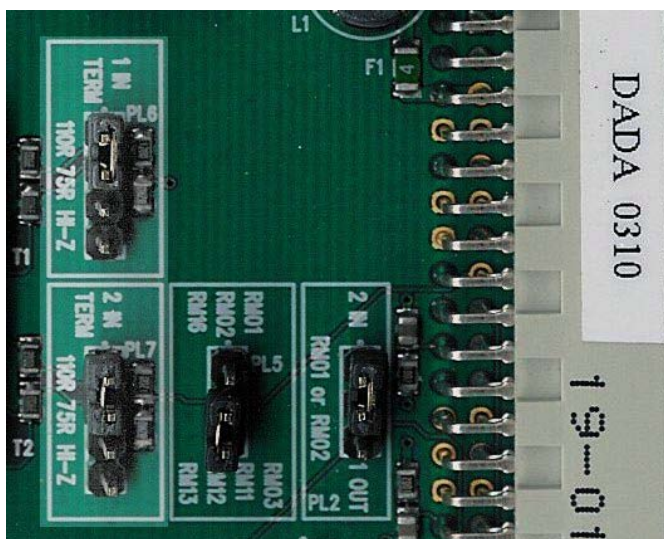

Configuration jumpers PL6 and PL7 can be found near the edge connector of the board.

3.4 Selecting single or dual channel mode

The DADA208 may be configured as a single channel (1 x 8) or dual channel (2 x 4) digital audio distribution amplifier using the board edge switch.



The channel mode is selected by changing the input source for channel 2 using S1 switch 2 as follows:

DADA208 single/dual configuration	PL12 Position
4+4 outputs (2-channel mode)	CH2 (up)
8 outputs, all from input 1 (1-channel mode)	CH1 (down)

3.5 Configuring the second channel input

The second channel input requires that jumper PL5 is placed in accordance with the following table:

Rear Module	PL5 position
RM01, RM02, RM09, RM10, RM16	RM01, RM02, RM16 (top)
RM03, RM11, RM12, RM13, RM21, RM35	RM03, RM11, RM12, RM13 (bottom)

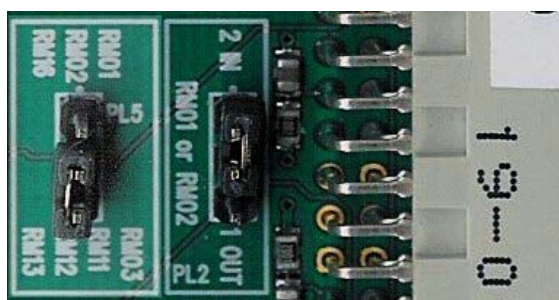

This information is also available in the pin-out tables for each rear connector.

Configuration jumper PL5 can be found near the edge connector of the board.

3.6 Obtaining an extra output in 1-channel mode

When the distribution amplifier is in 1-channel mode with an RM01, RM02 or RM10 rear connector it is possible to configure the second channel input connection as an output using PL2 as follows:

'CH2 IN' (RM01), '2' (RM02/RM10)	PL2 position
Channel 2 input	2 IN (top - default)
Output in 1-channel mode	1 OUT (bottom)



This information is also available in the pin-out tables for each rear connector.

Configuration jumper PL2 can be found near the edge connector of the board.

3.7 Universal rear connector pinout

75Ω digital audio connections with RM01

RM01 fits in all frames	Description
	RM01 (ZLA00091 artwork) <ul style="list-style-type: none"> • 24 modules in 4U, 12 modules in 2U, 6 in 1U & 2 in a DTB • All frame slots can be used

BNC	Dual-channel configuration	Single-channel configuration
CH2 OUT(1)	Output CH2	Output CH1
CH1 IN	Input CH1	Input CH1
CH1 OUT(1)	Output CH1	Output CH1
CH2 IN	Input CH2*	Output CH1*
CH1 OUT(2)	Output CH1	Output CH1
CH2 OUT(2)	Output CH2	Output CH1

Note: *Channel 2 input can be configured as an output if PL2 is moved to the '1 OUT' position.

DADA208 input link & output board configuration:-

PL6 position	PL7 position	PL2 position	PL5 position
75R	75R	See note.	RM01, RM02, RM16

Output module type	Output module position
OPAES75	RM01, RM02, RM16

75Ω digital audio connections with RM09 (obsolete)

RM09 fits in all frames	Description
 <p>OUT 4 OUT 3 OUT 2 OUT 1 LOOP-IN IN</p> <p style="text-align: center;">RM09</p>	<p>RM09 (ZLA00092 artwork)</p> <ul style="list-style-type: none"> • 24 modules in 4U, 12 modules in 2U, 6 in 1U & 2 in a DTB • All frame slots can be used

BNC	Dual-channel configuration	Single-channel configuration
IN	Input CH 1	Input CH1
LOOP IN	Input CH1 Loop-Through	Input CH 1 Loop-Through
OUT 1	Output CH 1	Output CH1
OUT 2	Input CH 2*	Not used
OUT 3	Output CH 1	Output CH1
OUT 4	Output CH 2	Output CH1

Note: *Channel 2 input can NOT be configured as an extra output.

DADA208 input link & output board configuration:-

PL6 position	PL7 position	PL2 position	PL5 position
Hi-Z or 75R	75R	2 IN	RM01, RM02, RM16

Output module type	Output module position
OPAES75	RM01, RM02, RM16

75Ω digital audio connections with RM16

RM16 fits in all frames	Description
	RM16 (ZLA000152 artwork) <ul style="list-style-type: none"> • 12 modules in 4U, 6 modules in 2U , 3 in 1U, 1 in a DTB • 1 module per rear connector • 6 connections available • Card fits in upper slot • No card fits in lower slot

BNC	Dual-channel configuration	Single-channel configuration
OUT 1A	Output CH 1	Output CH 1
CH2 IN	Input CH 2	Not used
OUT 1C	Output CH 1	Output CH 1
OUT 1D	Output CH 1	Output CH 1
OUT 2B	Output CH 2	Output CH 1
OUT 2D	Output CH 2	Output CH 1
CH1 IN	Input CH 1	Input CH 1
LOOP IN CH1	Input CH 1 Loop-Through	Input CH 1 Loop-Through
OUT 1B	Output CH 1	Output CH 1
OUT 2A	Output CH 2	Output CH 1
N/C	No connection	No connection
OUT 2C	Output CH 2	Output CH 1

Note: *Channel 2 input can NOT be configured as an extra output.

DADA208 input link & output board configuration:-

PL6 position	PL7 position	PL2 position	PL5 position
Hi-Z or 75R	75R	2 IN	RM01, RM02, RM16

Output module type	Output module position
OPAES75	RM01, RM02, RM16

75Ω digital audio connections with RM02

RM02 fits in a 2U or 4U frame	Description
	<p>RM02</p> <ul style="list-style-type: none"> • 18 modules per 4U frame • 9 modules per 2U frame • 3 modules per rear connector • 9 connections available • Card 1 fits in slots 1, 5 and 9 • Card 2 fits in slots 2, 6 and 10 • Card 3 fits in slots 4, 8 and 12 • No card fits in 3, 7 or 11

BNC	Dual-channel configuration	Single-channel configuration
A	Input 1	Input 1
B	Output 1	Output 1
C	Input 2*	Output 1*
D	Output 1	Output 1
E	Output 1	Output 1
F	Output 2	Output 1
G	Output 2	Output 1
H	Output 2	Output 1
I	Output 2	Output 1

Note: *Channel 2 input can be configured as an output if PL2 is moved to the '1 OUT' position.

DADA208 input link & output board configuration:-

PL6 position	PL7 position	PL2 position	PL5 position
75R	75R	See note.	RM01, RM02, RM16
Output module type		Output module position	
OPAES75		RM01, RM02, RM16	

75Ω digital audio connections with RM10 (obsolete)

RM10 fits in a 2U or 4U frame	Description
	<p>RM10 (ZLA000121 artwork)</p> <ul style="list-style-type: none"> • 18 modules per 4U frame • 9 modules per 2U frame • 3 modules per rear connector • 9 connections available • Card 1 fits in slots 1, 5 and 9 • Card 2 fits in slots 2, 6 and 10 • Card 3 fits in slots 4, 8 and 12 • No card fits in 3, 7 or 11

BNC	Dual-channel configuration	Single-channel configuration
LOOP-IN	Input 1	Input 1
LOOP-IN	Input 1 Loop-Through	Input 1 Loop-Through
1	Output 1	Output 1
2	Input 2*	Output 1*
3	Output 1	Output 1
4	Output 1	Output 1
5	Output 2	Output 1
6	Output 2	Output 1
7	Output 2	Output 1

Note: *Channel 2 input can be configured as an output if PL2 is moved to the '1 OUT' position.

DADA208 input link & output board configuration:-

PL6 position	PL7 position	PL2 position	PL5 position
Hi-Z or 75R	75R	See note.	RM01, RM02, RM16

Output module type	Output module position
OPAES75	RM01, RM02, RM16

110ΩIN/75ΩOUT digital audio connections with RM13

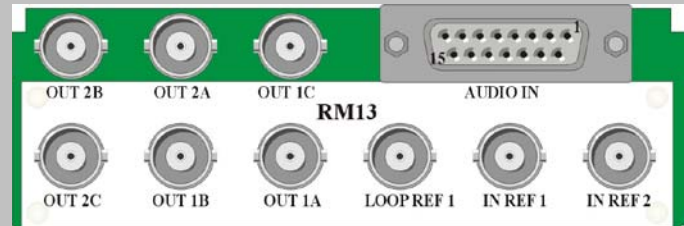
RM13 fits in all frames	Description
	RM13 (ZLA000118 artwork) <ul style="list-style-type: none"> • 12 modules in 4U, 6 modules in 2U , 3 in 1U, 1 in a DTB • 1 module per rear connector • 6 connections available • Card fits in upper slot • No card fits in lower slot

110Ω digital audio In 15-way D-type socket

Pin	Dual-channel configuration	Single-channel configuration
10	Audio Input 1 +	Audio Input 1 +
9	Audio Input 1 -	Audio Input 1 -
1	Input 1 Screen	Input 1 Screen
2	Input 2 +	Not used
3	Input 2 -	Not used
14	Input 2 Screen	Not used

75Ω digital audio out **BNC**

BNC	Dual-channel configuration	Single-channel configuration
Out 1A	Output 1	Output 1
Out 1B	Output 1	Output 1
Out 1C	Output 1	Output 1
Out 2A	Output 2	Output 1
Out 2B	Output 2	Output 1
Out 2C	Output 2	Output 1
IN REF1	No Connection	No Connection
IN REF2	No Connection	No Connection
LOOP REF1	No Connection	No Connection

DADA208 input link & output board configuration:-

PL6 & PL7 position	PL2 position	PL5 position
110R	2 IN	RM03, RM11, RM12, RM13

Output module type	Output module position
OPAES75	RM03, RM11, RM12, RM13

110ΩIN/75ΩOUT digital audio connections with RM21

RM21 fits in all frames	Description
	RM21 (ZLA000155 artwork) <ul style="list-style-type: none"> • 24 modules in 4U, 12 modules in 2U, 6 in 1U & 2 in a DTB • All frame slots can be used

110Ω digital audio In 15-way D-type socket

Pin	Dual-channel configuration	Single-channel configuration
10	Audio Input 1 +	Audio Input 1 +
9	Audio Input 1 -	Audio Input 1 -
1	Input 1 Screen	Input 1 Screen
2	Input 2 +	Not used
3	Input 2 -	Not used
14	Input 2 Screen	Not used

75Ω digital audio out BNC

BNC	Dual-channel configuration	Single-channel configuration
Out 1A	Output 1	Output 1
Out 1B	Output 1	Output 1
Out 2A	Output 2	Output 1
Out 2B	Output 2	Output 1

DADA208 input link & output board configuration:-

PL6 & PL7 position	PL2 position	PL5 position
110R	2 IN	RM03, RM11, RM12, RM13

Output module type	Output module position
OPAES75	RM03, RM11, RM12, RM13

75ΩIN/110ΩOUT digital audio connections with RM12

RM12 fits in all frames	Description
	RM12 (ZLA00095 artwork) <ul style="list-style-type: none"> • 24 modules in 4U, 12 modules in 2U, 6 in 1U & 2 in a DTB • All frame slots can be used

75Ω digital audio in BNC

BNC	Dual-channel configuration	Single-channel configuration
1	AES input 1	AES input 1
2	AES input 2	Not used

110Ω digital audio out 25-way D-type socket

Pin	Dual-channel configuration	Single-channel configuration
5	Output 1 +	Output 1 +
6	Output 1 -	Output 1 -
7	Output 1 +	Output 1 +
8	Output 1 -	Output 1 -
18	Output 1 +	Output 1 +
19	Output 1 -	Output 1 -
20	Output 1 +	Output 1 +
21	Output 1 -	Output 1 -
4	Output 1 Screen	Output 1 Screen
9	Output 2 +	Output 1 +
10	Output 2 -	Output 1 -
11	Output 2 +	Output 1 +
12	Output 2 -	Output 1 -
22	Output 2 +	Output 1 +
23	Output 2 -	Output 1 -
24	Output 2 +	Output 1 +
25	Output 2 -	Output 1 -
13	Output 2 Screen	Output 1 Screen

DADA208 input link & output board configuration:-

PL6 & PL7 position	PL2 position	PL5 position
75R	2 IN	RM03, RM11, RM12, RM13

Output module type	Output module position
OPAES110	RM03, RM11, RM12, RM13

110ΩIN/110ΩOUT digital audio connections with RM11

RM11 fits in all frames	Description
 <p>Audio Out Ref In Audio In</p> <p>ZLA00093 RM11</p>	<p>RM11 (ZLA00093 artwork)</p> <ul style="list-style-type: none"> • 24 modules in 4U, 12 modules in 2U, 6 in 1U & 2 in a DTB • All frame slots can be used

110Ω digital audio in 15 way D-type socket

Pin	Dual-channel configuration	Single-channel configuration
10	Audio Input 1 +	Audio Input 1 +
9	Audio Input 1 -	Audio Input 1 -
1	Input 1 Screen	Input 1 Screen
2	Input 2 +	Not used
3	Input 2 -	Not used
14	Input 2 Screen	Not used

110Ω digital audio out 26 way High Density D-type socket

Pin	Dual-channel configuration	Single-channel configuration
10	Output 1 +	Output 1 +
11	Output 1 -	Output 1 -
12	Output 1 +	Output 1 +
13	Output 1 -	Output 1 -
14	Output 1 +	Output 1 +
15	Output 1 -	Output 1 -
16	Output 1 +	Output 1 +
17	Output 1 -	Output 1 -
9	Output 1 Screen	Output 1 Screen
2	Output 2 +	Output 1 +
3	Output 2 -	Output 1 -
4	Output 2 +	Output 1 +
5	Output 2 -	Output 1 -
6	Output 2 +	Output 1 +
7	Output 2 -	Output 1 -
8	Output 2 +	Output 1 +
18	Output 2 -	Output 1 -
19	Output 2 Screen	Output 1 Screen

DADA208 input link & output board configuration:-

PL6 & PL7 position	PL2 position	PL5 position
110R	2 IN	RM03, RM11, RM12, RM13

Output module type	Output module position
OPAES110	RM03, RM11, RM12, RM13

Note: Ref In BNC is not used.

110ΩIN/110ΩOUT digital audio connections with RM03

RM03 fits in all frames	Description
	RM03 (ZLA00096 artwork) <ul style="list-style-type: none"> • 24 modules in 4U, 12 modules in 2U, 6 in 1U & 2 in a DTB • All frame slots can be used

110Ω digital audio in 15 way D-type socket

Pin	Dual-channel configuration	Single-channel configuration
10	Audio Input 1 +	Audio Input 1 +
9	Audio Input 1 -	Audio Input 1 -
1	Input 1 Screen	Input 1 Screen
2	Input 2 +	Not used
3	Input 2 -	Not used
14	Input 2 Screen	Not used

110Ω digital audio out 25-way D-type socket

Pin	Dual-channel configuration	Single-channel configuration
5	Output 1 +	Output 1 +
6	Output 1 -	Output 1 -
7	Output 1 +	Output 1 +
8	Output 1 -	Output 1 -
18	Output 1 +	Output 1 +
19	Output 1 -	Output 1 -
20	Output 1 +	Output 1 +
21	Output 1 -	Output 1 -
4	Output 1 Screen	Output 1 Screen
9	Output 2 +	Output 1 +
10	Output 2 -	Output 1 -
11	Output 2 +	Output 1 +
12	Output 2 -	Output 1 -
22	Output 2 +	Output 1 +
23	Output 2 -	Output 1 -
24	Output 2 +	Output 1 +
25	Output 2 -	Output 1 -
13	Output 2 Screen	Output 1 Screen

DADA208 input link & output board configuration:-

PL6 & PL7 position	PL2 position	PL5 position
110R	2 IN	RM03, RM11, RM12, RM13

Output module type	Output module position
OPAES110	RM03, RM11, RM12, RM13

110ΩIN/110ΩOUT digital audio connections with RM35

RM35 fits in all frames	Description
	RM35 <ul style="list-style-type: none"> • 24 modules in 4u, 12 modules in 2U, 6 in 1U & 2 in a DTB • All frame slots can be used

110Ω digital audio in

Pin	Dual-channel configuration	Single-channel configuration
a2	Audio Input 1 -	Audio Input 1 +
a3	Audio Input 1 +	Audio Input 1 -
a4	Input 1 Screen	Input 1 Screen
a5	Input 2 +	Not used
a6	Input 2 -	Not used
c4	Input 2 Screen	Not used

110Ω digital audio out

Pin	Dual-channel configuration	Single-channel configuration
c21	Output 1 +	Output 1 +
c22	Output 1 -	Output 1 -
c24	Output 1 +	Output 1 +
c25	Output 1 -	Output 1 -
a21	Output 1 +	Output 1 +
a22	Output 1 -	Output 1 -
a24	Output 1 +	Output 1 +
a25	Output 1 -	Output 1 -
a23	Output 1 Screen	Output 1 Screen
c23	Output 1 Screen	Output 1 Screen
a26	Output 1 Screen	Output 1 Screen
c26	Output 1 Screen	Output 1 Screen
c27	Output 2 +	Output 1 +
c28	Output 2 -	Output 1 -
c30	Output 2 +	Output 1 +
c31	Output 2 -	Output 1 -
a27	Output 2 +	Output 1 +
a28	Output 2 -	Output 1 -
a30	Output 2 +	Output 1 +
a31	Output 2 -	Output 1 -
a29	Output 2 Screen	Output 1 Screen
c29	Output 2 Screen	Output 1 Screen
a32	Output 2 Screen	Output 1 Screen
c32	Output 2 Screen	Output 1 Screen
c13&c14		GPI_1 & GPI_2
a1, a20, c2, c20		GND - ground
a14-19, c1, c3, c5-12 c15-19		NC - no user connection

DADA208 input link & output board configuration:-

When using the RM35 set the board links and sub PCB to the following positions.

PL6 & PL7 position	PL2 position	PL5 position
110R	2 IN	RM03, RM11, RM12, RM13

Output module type	Output module position
OPAES110	RM03, RM11, RM12, RM13

Note: RM35 can be used for 75Ω operation, set DADA208 to 75Ω and use +ve and screen connections only.

3.8 General purpose interface

GPI outputs use switch-closure to indicate status. When closed-circuit, the GPI line is connected to Frame Ground. As supplied, each GPI output can drive a 5V LED. For 24V bulb drive, resistors R3 and R6 must be changed to 0R0, 0805 types.

R3 and R6 are the outer pair of the block of four resistors adjacent to Q1 and Q2 near the edge connector.

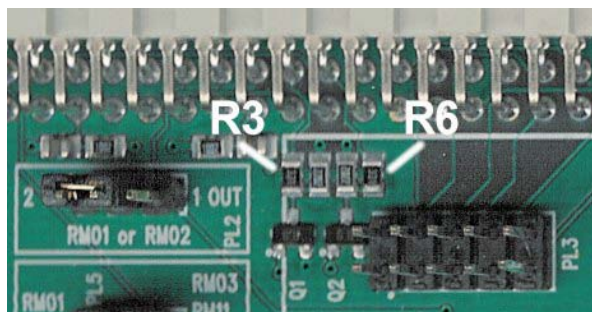

GPI	Closed-circuit (Ground)	Open-circuit
'a'	Input 1 absent	Input 1 present
'b'	Input 2 absent	Input 2 present
'c'	Not used	Not used
'd'	Not used	Not used
'e'	Not used	Not used
'f'	Not used	Not used

2U frame GPI Connections

GPI lines 'a' to 'f' of each card connect to one of four rear remote connectors as follows:

Slot no.	'a' pin	'b' pin	'c' pin	'd' pin	'e' pin	'f' pin
1	8 (1)	9 (1)	18 (1)	26 (1)	19 (2)	20 (2)
2	7 (1)	16 (1)	17 (1)	25 (1)	10 (2)	11 (2)
3	8 (3)	9 (3)	18 (3)	26 (3)	19 (4)	20 (4)
4	7 (3)	16 (3)	17 (3)	25 (3)	10 (4)	11 (4)
5	5 (1)	6 (1)	15 (1)	24 (1)	1 (2)	2 (2)
6	4 (1)	14 (1)	13 (1)	23 (1)	3 (2)	4 (2)
7	5 (3)	6 (3)	15 (3)	24 (3)	1 (4)	2 (4)
8	4 (3)	14 (3)	13 (3)	23 (3)	3 (4)	4 (4)
9	3 (1)	12 (1)	22 (1)	21 (1)	12 (2)	13 (2)
10	10 (1)	11 (1)	19 (1)	20 (1)	21 (2)	22 (2)
11	3 (3)	12 (3)	22 (3)	21 (3)	12 (4)	13 (4)
12	10 (3)	11 (3)	19 (3)	20 (3)	21 (4)	22 (4)

Table shows Pin number (Remote number)

Note: Remote 1 and Remote 3 are 26 way high density 'D' type female sockets and frame ground is pin 2 and +5V @500mA is pin 1 in each case.
Remote 2 and Remote 4 are 26 way high density 'D' type male plugs and frame ground is pin 6 and +5V @500mA is pin 15 in each case.

1U frame GPI connections

GPI lines 'a' to 'f' of each card connect to one of two rear remote connectors as follows:

Slot no.	'a' pin	'b' pin	'c' pin	'd' pin	'e' pin	'f' pin
1	8 (1)	9 (1)	18 (1)	26 (1)	19 (2)	20 (2)
2	7 (1)	16 (1)	17 (1)	25 (1)	10 (2)	11 (2)
3	5 (1)	6 (1)	15 (1)	24 (1)	1 (2)	2 (2)
4	4 (1)	14 (1)	13 (1)	23 (1)	3 (2)	4 (2)
5	3 (1)	12 (1)	22 (1)	21 (1)	12 (2)	13 (2)
6	10 (1)	11 (1)	19 (1)	20 (1)	21 (2)	22 (2)

Table shows Pin number (Remote number)

Note: Remote 1: 26 way high density D-type socket. Frame ground is pin 2 and +5V @500mA is pin 1.
Remote 2: 26 way high density D-type plug. Frame ground is pin 6 and +5V @500mA is pin 15.

DTB GPI connections

GPI lines 'a' to 'f' of each card connect to the rear remote connector as follows:

Slot no.	'a' pin	'b' pin	'c' pin	'd' pin	'e' pin	'f' pin
1	1	2	3	4	5	6
2	9	10	11	12	13	14

Note: Remote connector is 15 way normal density D-type socket. Frame ground is pin 15.

4 Problem solving

Basic fault finding guide

The PSU LED is not illuminated

Check that the frame PSU is functioning – refer to the appropriate frame manual for detailed information

Check that the card is seated correctly in the frame

There is no audio output

Check that valid digital audio is present and that any cabling is intact

The second channel input does not work

Check that a valid digital audio input is present and that any cabling is intact

Check that the input source set for the second set of outputs is set for Input 2 – (dual channel mode)

Check the position of PL5 and PL2 for the rear connector is use

The second set of outputs do not work

Check that a valid digital audio input is present and that any cabling is intact

Check that the input source set for the second set of outputs is set for Input 1 – (single channel mode)

The card no longer responds to card edge control

Check that the card is seated correctly and that the PSU LED is lit

If necessary re-set the card

Re-setting the card

If required, the card may be reset by simply removing the rack power and re-applying power after a few seconds or by removing the card from the rack and then re-inserting the card

It is safe to re-insert the card whilst the rack is powered

5 Specification

General

Dimensions	100mm x 266 mm module with DIN 41612 connector
Weight	140g
Power consumption	0.6 W

Inputs

Digital audio	2 AES/EBU at 28.4kHz to 100kHz Input impedance: 110 Ω , 75 Ω , or high-impedance, selected by jumper links
---------------	---

Outputs

Number and type:	8 (4 per channel) AES/EBU Output impedance: 110 Ω or 75 Ω selected by output module
------------------	--

GPI lines

Outputs:	2 (D-type on frame) Input presence/absent for each channel
----------	---

Status monitoring

LED display	Front of card edge visual monitoring with LED indicators to indicate: PSU rails present Inputs present
-------------	--

Ordering information

DADA208	Dual channel digital audio distribution amplifier w/manual control
Indigo 4	4U frame without active control panel for up to 24 modules
Indigo 2	2U frame without active control panel for up to 12 modules
Indigo 1	1U frame without active control panel for up to 6 modules
Indigo DT	1U Desk top box without active control panel for up to 2 modules
Indigo 2A	2U frame with active control panel for up to 12 modules
Indigo 1A	1U frame with active control panel for up to 6 modules
Indigo DTA	1U Desk top box with active control panel for up to 2 modules
Indigo 2S	Statesman enabled only 2U frame for up to 12 modules
Indigo 1S	Statesman enabled only 1U frame for up to 6 modules
Indigo DTS	Statesman enabled only 1U Desk top box for up to 2 modules
RM01	Single slot rear module with 6 BNCs (2x75Ω in/2x75Ω out per channel)
RM09	Single slot rear module with 6 BNCs (2x75Ω in/1x75Ω out Ch1, 2x75Ω Ch2 with loop-through of Ch1)
RM03	Single slot rear module with 15 way input 'D' connector and 25 way 'D' output connector (2x110Ω in/4x110Ω out per channel)
RM11	Single slot rear module with 15 way input 'D' connector and 26 way High Density 'D' output connector (2x110Ω in/4x110Ω out per channel)
RM12	Single slot rear module with 2 BNC inputs and 25 way 'D' output connector (2x75Ω in/4x110Ω out per channel)
RM21	Single slot rear module with 4 BNC outputs and a 25 way 'D' input connector (2x110Ω in/2x75Ω out per channel)
RM02	Quad slot rear module with 27 BNCs for 3 boards (2x75Ω in/3x75Ω out of Ch1 and 4x75Ω output of Ch2)
RM10	Quad slot rear module with 27 BNCs for 3 boards (2x110Ω in/3x75Ω out per channel w/ input loop-through of Ch 1)
RM13	Dual slot rear module with 9 output BNCs and a 25 way 'D' input connector (2x110Ω in/3x75Ω out per channel)
RM16	Dual slot rear module with 12 BNCs. (2x75Ω in/4x75Ω out per channel with AES (BNC) loop-through of Ch1)
RM35	Single slot DADA rear module with easy solder 64 way audio connector.