

digital keying modular  
interface audio  
converters analogue video

**FR2AV**

2U frame

# USER MANUAL

Crystal  Vision

## **General Safety Summary**

Use only power cords that meet the required specification for this product.

This product must be grounded through the grounding conductor of the power cord.

Do not operate the equipment with covers or panels removed.

To avoid fire hazard use only fuses of the type and rating specified.

To avoid electric shock do not operate this product in wet or damp conditions.

To avoid injury or fire hazard do not operate this product in an explosive atmosphere.

To avoid overheating provide proper ventilation.

Only use this rack in conjunction with Crystal Vision modules designed for that purpose.

Do not use the frame unless all the rear connector positions are filled, either with Crystal Vision Rear Modules, or with Crystal Vision blanking plates.

Only suitably trained personnel should perform service procedures.

Apart from procedures described in this manual there are no user serviceable parts within the frame. If the frame requires any other servicing it should be returned to the manufacturer or dealer.

**CAUTION** These servicing instructions are for use by qualified personnel only. To reduce risk of electric shock, do not perform any servicing other than that contained in the Operating Instructions unless you are qualified to do so. Refer all servicing to qualified service personnel.

Explanation of symbols used on the equipment



Protective ground connection.



Refer to the user manual.

# FR2AV FRAME USERS MANUAL

FR2AV FRAME issue 111 Manual.doc    BF 22/07/01  
FR2AV S/W                                    1.5 onwards

## CONTENTS

GENERAL SAFETY SUMMARY .....	2
INTRODUCTION.....	4
SPECIFICATION .....	5
MAINS CONNECTIONS.....	5
POWER SUPPLIES.....	5
FRONT PANEL INDICATION OF SUPPLY STATUS.....	5
VIDEO/AUDIO CARDS.....	6
REAR SIGNAL CONNECTIONS .....	6
SLOT NUMBERS.....	7
REMOTE CONTROL / GPI CONNECTIONS.....	7
FP2-LF LCD FRONT PANEL CONTROL MODULE ON THE FR2AV FRAME. ....	10
<i>Using the Front Panel Controls.....</i>	<i>10</i>
<i>Controlling Two Frames From One Panel.....</i>	<i>10</i>
REMOTE CONTROL PANELS .....	11
<i>REMIU.....</i>	<i>11</i>
<i>REMIUS.....</i>	<i>12</i>
<i>PAN-XKEY.....</i>	<i>12</i>
MAINTENANCE.....	12
<i>Replacing the rear Cooling Fan.....</i>	<i>12</i>
<i>Replacing the mains input fuses.....</i>	<i>13</i>

## Introduction

The FR2AV frame provides the connections and supplies for up to 12 Crystal Vision video or audio modules in 2U of rack height. The frames provide configurable rear connections and the facility for two separate plug-in power supplies. The dual supply facility allows for redundancy and continued operation in the event of a power supply failure. A hinged front panel provides access to the power supply unit and all of the modules.

The inside of the frame can be accessed to change the modules by unscrewing the two thumbscrews, one at each side, and pulling the panel forward. The panel can then be allowed to hinge down, giving access to the board slots inside the frame. Although it is possible to operate the frame with the front panel open this should not be done as the frame may not meet electromagnetic compatibility (EMC) requirements in this condition.

Signal modules can be removed simply by pulling on the handle and withdrawing them from the frame. They are inserted by feeding the board into the appropriate guides and pushing it fully home. The power supply module is inserted and removed in the same way. The signal and power supply modules have allocated slots and are not interchangeable. Hazardous voltages may be present within the power supply module even when it is disconnected from the frame. **DO NOT REMOVE THE SAFETY COVERS FROM THIS UNIT.**

A fused IEC mains input is provided for each power supply module. The universal input power supplies used can accept voltages between 85 and 264V rms. Each mains input must include a protective ground connection. The fuse holder is part of the mains inlet must be disconnected before the fuse can be accessed. Replace the fuse only with one of the same type and rating.

Two cooling fans are provided, one on a detachable plate on the rear of the frame and is operated continuously, the other is fitted on the front panel and under normal operating conditions is not in operation, however if the temperature sensor fitted on one or both of the power supply modules detect that the temperature inside the frame has exceeded a defined limit, then the front fan is activated to assist in the cooling.

Optional Front Panel Controls FP2-LF with LCD display and keyboard allows easy user adjustment of suitable Crystal Vision modules with a menu driven user interface.

Standard front panel FR2AV UNIVERSAL FRAME

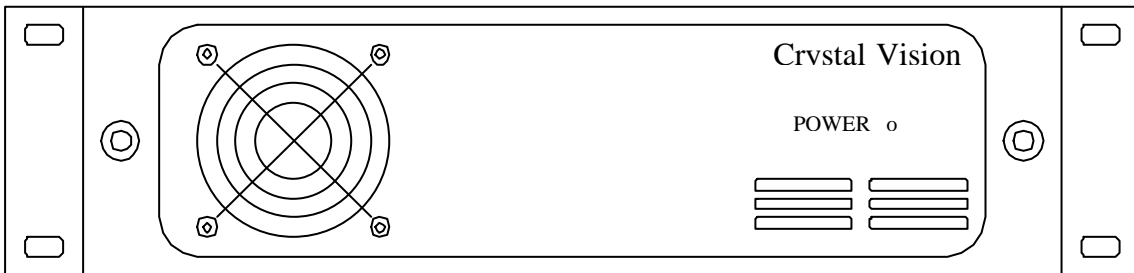

## **Specification**

Size (mm)	482 (w) X 89 (h) X 504 (d)
Weight	4.7 Kg
Supply Voltage	110 – 240V 47 – 400 Hz
Temperature Range	0 – 40 °C

## **Mains Connections**

The frame is connected to the mains supplies by means of one or two detachable power cords.

**CAUTION:** To reduce the risk of electric shock, if two power supply cords are used plug each power supply cord into separate branch circuits employing separate service grounds.

Any power cord used should be fitted with an IEC 320 female connector. It should have a minimum current rating of 6A. It should meet the relevant local safety standards.

## **Power Supplies.**

The frame has dedicated slots for up to two Crystal Vision power supply modules. The dual supply capability provides redundancy and continued operation in the event of the failure of one of the supply modules.

The power supply modules are available in 75W and 150W versions. If two supplies are fitted they should both be the same version.

The power supplies can be inserted and removed while the system is powered without damage. There are no user serviceable parts inside the power supply module covers. The safety covers should not be removed even when the module is disconnected.

The power supplies have LED's to provide an indication of status, and provide a changeover relay contact on a rear connector for system status monitoring. Further information is given in the relevant sections of this manual. Refer to the power supply module documentation for information about the LED's, and about replacing the fuses on the power supply modules.

## **Front Panel Indication Of Supply Status**

A signal from the each of the power supplies is routed through the frame wiring to the front panel electronics. This allows an indication of status to the user. The fault condition indicated is a supply rail failure or a power supply module overheating. Overheating will probably be due to a ventilation blockage or fan failure. Note under these conditions the fan fitted on the front panel will be activated. See the “maintenance” section for information on fan replacement.

With an FR2AV the power indication LED will change from green to red if one of the power supplies develops a fault ( the red fail LED on the front of the associated power supply will also light up ). The position of the link on header J2 depends on the number of power supplies in the frame. If only one power supply is fitted the link should be between pins 1 and 2, closer to the ribbon cable connector. If two supplies are fitted the link should be between pins 2 and 3, away from the ribbon cable connector.

With an FP2-LF with LCD display , the fault indication is the text “Warning Power Supply or Fan Problem” on the control panel display. This will be displayed for two seconds at twenty second intervals. The position of the link on header J2 on the control panel board depends on the number of

power supplies in the frame. J2 is the middle of the three headers visible through a cut-out on the left of the control panel cover. If only one power supply is fitted the link should be towards the edge of the control panel assembly. If two power supply modules are fitted the link on J2 should be towards the middle of the control panel assembly.

In addition to the front panel indication the power supply status is indicated through a set of relay contacts as described in the section on remote control and GPI connections.

In addition to the front panel indication the power supply status is indicated through a set of relay contacts as described in the section on remote control and GPI connections.

## ***Video/Audio cards***

The frame has twelve slots for Crystal Vision video or audio cards. Only Crystal Vision cards should be fitted. The signal connections to these are made through rear modules. The operation and connections of each card and associated rear modules are described in the documentation relating to that card. All Crystal Vision cards can be inserted and removed while the frame is powered without damage.

Typical Rear Module for one slot position ( RM01 with label attached for PAL/NTSC to SDI decoder )

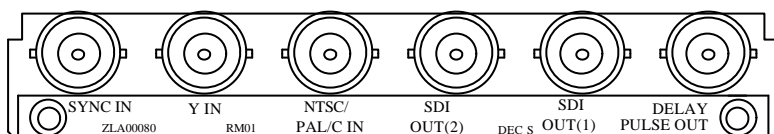

## ***Rear Signal Connections***

The signal connections to the cards are made through a range of rear modules. The frame will be supplied with an appropriate selection of these for the cards installed in it. Unused slots will be fitted with blanking plates. Details of signal types and pin-outs are given the documentation supplied with each Crystal Vision video or audio card.

The rear modules are held in place by a retaining bar at each side. These run the height of the frame and provide mechanical support as well as ensuring EMC compliance.

It is possible to move, add, or change the rear modules if new or different cards are to be used in the frame. This should be done as follows: -

1. Disconnect the mains power leads from the frame.
2. Identify the rear modules or blanking plates to be removed. Using a cross-head screwdriver undo the three captive screws on the retaining bar on each side of these module(s). Remove the retaining bars. Note on some full height (Quad ) rear modules such as the RM02, RM10 and RM19 the retaining bars for each side of the rear module have only two captive screws, one at each end ,in this case the centre position of the retaining bar is held in by a M3 x 8mm screw.
3. Pull the rear module(s) straight off the rear of the frame.
4. Check that the rear modules that will be fitted to the frame have the relevant labels properly attached using the retaining pins.
5. Fit the new modules by pushing them straight on to the connectors.
6. Hold any blanking plates in place while the retaining bars are refitted. Ensure that both screws on the retaining bar is fully tightened to maintain mechanical integrity and EMC compliance.
7. To maintain product safety and EMC compliance the rear of the frame should be filled with Crystal Vision connector units and blanking plates before power is reapplied.

## Slot Numbers

The diagram below shows the positions of the slots in the frame when viewed from the front.

Signal Card Slot Numbers

1	5	9	upper power supply
2	6	10	
3	7	11	lower power supply
4	8	12	

## Remote Control / GPI Connections

The High-density D-type connectors on the rear of the frame contain six connections associated with each of the six signal card slots. These are given the letters 'a' to 'f' in the documentation supplied with the Crystal Vision video or audio card. Depending on the type of card and its configuration these may be RS422 or GPI connections. The following tables should be used together with the card documentation to determine the signal connections. To maintain EMC compliance only good quality screened cable assemblies should be used.

### Remote 1 and Remote 3 connections ( 26 way high density D-type socket )

Pin number	Remote 1- function	Remote 3 - function
1	+5.3V +/- 10% dc out	+5.3V +/- 10% dc out
2	Frame GND	Frame GND
3	Slot 9 GPI 'a'	Slot 11 GPI 'a'
4	Slot 6 GPI 'a'	Slot 8 GPI 'a'
5	Slot 5 GPI 'a'	Slot 7 GPI 'a'
6	Slot 5 GPI 'b'	Slot 7 GPI 'b'
7	Slot 2 GPI 'a'	Slot 4 GPI 'a'
8	Slot 1 GPI 'a'	Slot 3 GPI 'a'
9	Slot 1 GPI 'b'	Slot 3 GPI 'b'
10	Slot 10 GPI 'a'	Slot 12 GPI 'a'
11	Slot 10 GPI 'b'	Slot 12 GPI 'b'
12	Slot 9 GPI 'b'	Slot 11 GPI 'b'
13	Slot 6 GPI 'c'	Slot 8 GPI 'c'
14	Slot 6 GPI 'b'	Slot 8 GPI 'b'
15	Slot 5 GPI 'c'	Slot 7 GPI 'c'
16	Slot 2 GPI 'b'	Slot 4 GPI 'b'
17	Slot 2 GPI 'c'	Slot 4 GPI 'c'
18	Slot 1 GPI 'c'	Slot 3 GPI 'c'
19	Slot 10 GPI 'c'	Slot 12 GPI 'c'
20	Slot 10 GPI 'd'	Slot 12 GPI 'd'
21	Slot 9 GPI 'd'	Slot 11 GPI 'd'
22	Slot 9 GPI 'c'	Slot 11 GPI 'c'
23	Slot 6 GPI 'd'	Slot 8 GPI 'd'
24	Slot 5 GPI 'd'	Slot 7 GPI 'd'
25	Slot 2 GPI 'd'	Slot 4 GPI 'd'
26	Slot 1 GPI 'd'	Slot 3 GPI 'd'

**Remote 2 and Remote 4 connections ( 26 way high density D-type plug )**

Pin number	Remote 2- function	Remote 4 - function
1	Slot 5 GPI 'e'	Slot 7 GPI 'e'
2	Slot 5 GPI 'f'	Slot 7 GPI 'f'
3	Slot 6 GPI 'a'	Slot 8 GPI 'e'
4	Slot 6 GPI 'f'	Slot 8 GPI 'f'
5	Relay close on fault ,upper PSU	Relay close on fault ,lower PSU
6	Frame GND	Frame GND
7	RX+ RS422	N/C
8	Reserved for future use	N/C
9	Reserved for future use	N/C
10	Slot 2 GPI 'e'	Slot 4 GPI 'e'
11	Slot 2 GPI 'f'	Slot 4 GPI 'f'
12	Slot 9 GPI 'e'	Slot 11 GPI 'e'
13	Slot 9 GPI 'f'	Slot 11 GPI 'f'
14	Relay common , upper PSU	Relay common , lower PSU
15	+5.3V +/- 10% dc out	N/C
16	RX- RS422	N/C
17	TX- RS422	N/C
18	Reserved for future use	N/C
19	Slot 1 GPI 'e'	Slot 3 GPI 'e'
20	Slot 1 GPI 'f'	Slot 3 GPI 'f'
21	Slot 10 GPI 'e'	Slot 12 GPI 'e'
22	Slot 10 GPI 'f'	Slot 12 GPI 'f'
23	Relay open on fault ,upper PSU	Relay open on fault ,lower PSU
24	N/C	N/C
25	TX- RS422	N/C
26	Reserved for future use	N/C

Note the total current available from the above 5.3V dc outputs is limited to approximately 1.5A

The power supply module has a changeover relay to indicate voltage rail and thermal status. Details are given in a separate tables below.

<b>Upper Power Supply Relay Connections</b>	
<b>description</b>	<b>pin number</b>
relay common	Remote 2 pin 14
open on fault	Remote 2 pin 23
close on fault	Remote 2 pin 5

<b>Lower Power Supply Relay Connections</b>	
<b>description</b>	<b>pin number</b>
relay common	Remote 4 pin 14
open on fault	Remote 4 pin 23
close on fault	Remote 4 pin 5

Note the current though the relay contacts should be limited to a maximum of 200mA.



View from rear of FR2AV Frame showing rear connectors

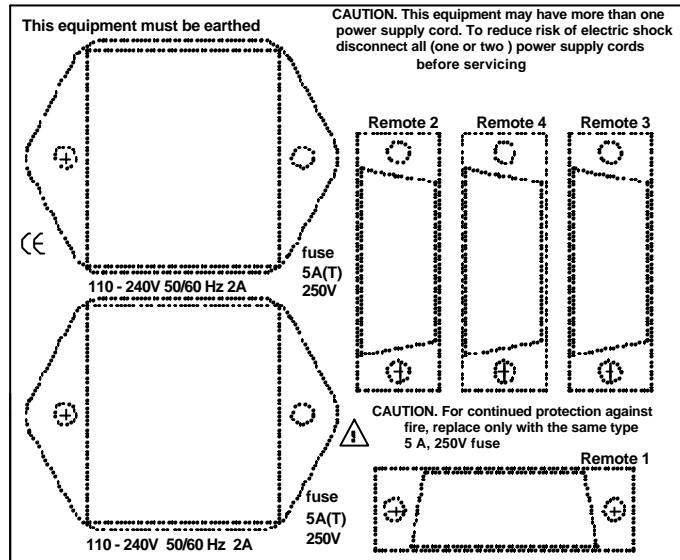

## **FP2-LF LCD Front Panel Control Module on the FR2AV Frame.**

### **Using the Front Panel Controls**

The front panel module FP2-LF fitted to the FR2AV frame allows control of suitable Crystal Vision Audio/Video cards without opening the frame front panel. Front panel control uses a two-line by twenty-character alphanumeric display to guide the user through the control process. The user has a number of buttons and an adjustment knob to select and adjust parameters.

The front panel module FP2-LF maintains a list of the boards available for control. Pressing the "DEVICE" button at any time will access this list. The display will give information about the number of cards available(which have the remote control facility), and about the type and position of the card currently selected. The position is expressed as a "node number".

The node number is determined by the slot number, and by the position of a configuration link in the frame. Details of setting the link position are given in the section "Controlling Two Frames From One Panel" below. Depending on this link the node address will either be: the slot number minus one (giving a node address range of 0 to 11) ; or the slot number plus fifteen (giving a node address range of 16 to 27).

It should be noted that some cards have a built-in HEX node switch ( to allow operation on older style frames ), this switch is usually labelled 'node' and is factory set to position 0. If it is set to another number, it may cause two cards in the frame to have the same node number, this will cause problems in communications between the front control panel and the cards. An indication of this is that the number , for showing, the number of cards available, will fluctuate every 10 seconds or so.

Turning the knob will scroll through the available cards. When the desired card is selected pressing the "ENTER" button will activate control for that card. The details of the menu structure depend on the card type and configuration. Consult the documentation supplied with the card for more detail.

Detail of display and buttons on front panel module FP2-LF

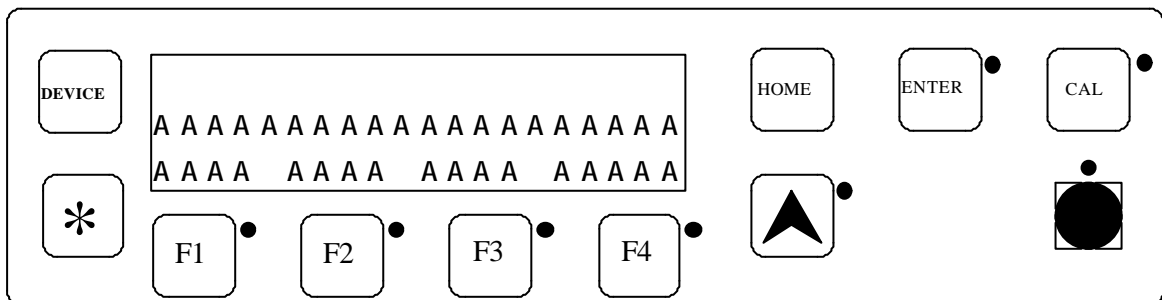

### **Controlling Two Frames From One Panel**

It is possible to configure and connect two frames so that the cards they contain are all controlled from the front panel module FP2-LF on one of the frames. The other frame must have no front panel control module. The two frames can be up to 100m apart depending on the type of cable used and the ambient electrical noise.

The cards in one frame will have node numbers in the range 0 to 11. The cards in the other will be in the range 16 to 27. A special cable must run between the "remote 2" D-type connectors of the two frames.

Selection of the higher node address range should be done before the frame is installed. The process involves:-

1. Remove the frame from its packaging and put it on a suitable working surface.
2. Remove the lid from the frame by unscrewing all the fixings with a cross-head screwdriver.
3. The links that select the node address are on the board that runs past the fan at the rear of the frame. They are labelled J1 and J2.
4. The links are normally set in position 1, closer to the fan. This selects the lower address range. To select the higher address range move both links J1 and J2 to position 3, further away from the fan, this will produce the node address range 16 to 27.
5. Replace the frame lid, making sure all the fixings are fully tightened to ensure continued EMC compliance. Cards inserted into the frame will now have node addresses in the higher range.
6. Replace the frame in its packing material to protect it until it is installed.

The cable required uses two 26 way high density D-type sockets. These should be connected with screened twisted pair cable containing two pairs. All the wiring is pin to pin links. Pins 16 and 7 should use one twisted pair, pins 17 and 25 the other. The screen should be connected to pin 6 on both connectors. To ensure continued EMC compliance only good quality screened cable should be used.

## REMOTE CONTROL PANELS

Crystal Vision offers the choice of three remote control panels which can be used when a requirement exists for panels and equipment to be located in different rooms.

### REM1U

The REM1U is a 1U remote control panel. 482mm (19 inches ) and 85mm deep. The REM1U can be powered by a mains adapter (supplied with REM1U) or via the dc power output on the FR2AV frame ( pin 15 of REMOTE 2). The mains adapter has a dc output voltage of +5.6Vdc which connects into a 3pin locking DIN connector on the rear of the REM1U. The REM1U can be powered from both at the same time.

A multi-core cable from the REM1U (remote A connector) plugs into the FR2AV frame (REMOTE 2 connector). If the REM1U is powered by the mains adapter , then the multi-core cable can be up 100m long ,however if the REM1U is powered only by the dc power output on pin 15 of REMOTE 2 connector then the cable is limited to 5m in length.

Details of cable to control one FR2AV frame

15 way D <b>plug</b> for Remote A on REM1U unit			26 way D <b>socket</b> for REMOTE 2 of FR2AV Frame.		
Pin	Function	Comment	Pin	Function	Comment
1	TX-		16	RX-	
2	TX+		7	RX+	
3	RX+		17	TX+	
4	RX-		25	TX-	
6-7	N/C				
8	GND		6	GND	
9-13	N/C				
14	+5.3V dc in		15	+5.3V dc out	FR2AV frame only
15	N/C				

Note the transmit TX on one end of the cable connects to the receive RX on the other end.

For long cables (up to 100m long) use two twisted pairs with overall screen. On the 15way pins 1 & 2 are a twisted pair, and the pins 3 & 4 are the other twisted pair.

For shorter cables ( up to 5m long) use 6 core cable with overall screen. To ensure continued EMC compliance only good quality screened cable should be used.

Note on older 2U frames such as FR2-12 there is no dc voltage output on pin 15 of the REMOTE 2 connector and therefore the mains adapter must be used to power the REM1U.

It is possible for the REM1U to control two FR2AV frames. In this case the multi-core cable from the REM1U connects to the first FR2AV frame as described in the above table, and then a cable loops out of the REMOTE 2 connector to another REMOTE 2 connector which is connected to a second FR2AV frame. This part of the cable is the same as described in the above section 'Controlling Two Frames From One Panel'. Note it is important that no connection are made between pin 15 (+5.3V) of the two REMOTE 2 connectors, and that both FR2AV frames have no control panels on the front, and that the node addresses of one FR2AV frame are different to the other FR2AV frame..

## REM1US

The REM1US is a 1U remote control panel. A slimline version of the REM1U at 231mm wide, it is ideal for insertion in a control desk. It plugs into frame remote 2 (26 way high density D-type **plug**). It can control up to two frames at once. It uses the same cable as REM1U.

## PAN-XKEY

The PAN-XKEY allows tactile operation of up to 12 LKEY211 or 12 SAFIRE modules in one frame. High quality buttons, T-bar and shaft encoders allow live control of keying products. A special remote cable is supplied by Crystal Vision to be connected between the PAN-XKEY and the frames rear remote connectors (remote 1 and remote 3). The PAN-XKEY is supplied with a mains adapter with dc output voltage of 5.3V.

## MAINTENANCE

**CAUTION** These servicing instructions are for use by qualified personnel only. To reduce risk of electric shock, do not perform any servicing other than that contained in the Operating Instructions unless you are qualified to do so. Refer all servicing to qualified service personnel.

### Replacing the rear Cooling Fan.

Two cooling fans are provided, one is fitted on a detachable plate on the rear of the frame and is operated continuously, the other is switchable, and is fitted on the front panel, and under normal operating conditions is not active, however if the temperature sensor fitted on one or both of the power supply modules detect that the temperature inside the frame has exceeded a defined limit, then the front fan is activated to assist in the cooling. If the temperature inside the frame is then reduced below the defined limit the front fan will stop, and if the temperature then increases again (this could take 1 to 3 minutes) above the limit the front fan will be activated again.

It is possible to replace the rear cooling fan (which is fitted on a detachable plate) at the rear of the frame without disconnecting any cables from the frame. Although it is possible to perform this operation with the frame still powered, **DO NOT DO THIS**, as the frame is likely to overheat with no cooling airflow.

The sequence is as follows.

1. Disconnect the power cord connected to the frame
2. Use a cross-head screwdriver to slacken the two captive screws that hold the fan mounting plate onto the rear side of the frame.
3. Slide the fan mounting plate backwards to free the retaining tabs.
4. Lift the fan mounting plate clear.
5. While supporting the weight of the fan and mounting plate, reach in through the mounting plate hole and disconnect the fan power connector.
6. Replace the fan with a Crystal Vision supplied replacement part to ensure adequate cooling and continued fire protection. Be sure to fit the finger guards on both sides of the fan/mounting plate assembly.
7. Reconnect the fan power connector
8. Fit the fan mounting plate tabs into the slots in the frame rear side. Be careful to position the fan wiring so that it will not touch the fan blades when the fan is in its final position.

9. Engage the two captive screws that hold the fan mounting plate onto the rear side of the frame.  
Fully tighten the screws with a cross-head screwdriver. Check that the screws are too tight to be undone without a screwdriver.
10. Reconnect the power supply cords.

## Replacing the mains input fuses

The mains input fuses are fitted inside the IEC 320 connectors at the rear of the frame. A spare fuse is also stored inside the connector. The fuse can only be accessed when the power cord is disconnected. The sequence is as follows: -

1. Disconnect ALL the power cords (one or two depending on configuration) from the rear of the frame.
2. Using a flat bladed screwdriver or similar tool gently lever out the fuse drawer from the relevant IEC connector using the tab visible at the bottom of the connector depression.
3. Remove the defective fuse and replace with either the spare fuse or with a 5A, 250V time delay fuse.
4. Replace the fuse drawer and reconnect the power cords.

If a fuse blows repeatedly this indicates a fault either in the associated power supply module or elsewhere. Return the frame and/or power supply to the manufacturer or dealer for repair.

End of document.